



## SMW-HR Wall Mount High Resolution Weighing Indicator/Controller



*User Manual*  
[www.mantracourt.co.uk](http://www.mantracourt.co.uk)

**ME** mantracourt

Contents Pages	
<b>Chapter 1 Introduction to SMW-HR</b> .....	<b>2</b>
<b>Chapter 2 Installing the SMW-HR</b> .....	<b>4</b>
Environmental Requirements .....	5
Conditions.....	5
Terminal Connections.....	5
<b>Chapter 3 The SMW-HR Controls and Parameters</b> .....	<b>7</b>
The Configurable Parameters.....	8
Section 1 User/Engineer - Configurable Parameters .....	8
Section 2 Calibrators - Configurable Parameters .....	9
<b>Chapter 4 Strain Gauge Input to the SMW-HR</b> .....	<b>12</b>
<b>Chapter 4 Strain Gauge Input to the SMW-HR</b> .....	<b>12</b>
The Strain Gauge Input .....	12
Calibration .....	13
4 Point Linearisation .....	13
<b>Chapter 5 Analogue Outputs</b> .....	<b>15</b>
Output Scaling.....	15
Method of Calculating OP LO and OP Hi from any known output values .....	15
Calibration .....	16
<b>Chapter 6 Relay Output Module</b> .....	<b>17</b>
Module Functions .....	17
Set Points (SP).....	17
In Flight Compensation .....	17
Hysteresis (HYS).....	18
Output Action (Action).....	18
Latching Outputs (LAtCH) .....	18
Figure 6.1 LR1 Module .....	18
<b>Chapter 7 The Communications Port</b> .....	<b>19</b>
Introduction .....	19
Serial Communication Protocol .....	19
MANTRABUS Format - selected when CP is 128.....	19
Operation .....	19
Updating.....	19
Communications Commands .....	20
Command 1 Request for all data:.....	20
Response to Command 1 .....	21
COMMAND 2 REQUEST DISPLAY DATA.....	22
Response to Command 2 .....	22
COMMANDS 4 TO 34: Write data to SMW-HR Parameter .....	22
Response to COMMAND 4 to 34 .....	22
MODBUS Protocol .....	23
MODBUS IMPLEMENTATION FOR HIGH RESOLUTION - CP = 130.....	23
Exception Responses .....	23
Register Allocation .....	24
ASCII Protocol .....	26
List of commands .....	28
SMW-HR Printer Interface .....	29
Additional Mnemonics for the Printer Operation:.....	29
<b>Chapter 8 Trouble Shooting Guide</b> .....	<b>33</b>
<b>Chapter 9 SMW-HR Specifications</b> .....	<b>34</b>
The Communications Port Data .....	35
SMW-HR Order Codes.....	36
Optional Modules .....	36
SMW-HR Accessories.....	36
Instrument Setup Record Sheet .....	37
W A R R A N T Y .....	38

## **Chapter 1 Introduction to SMW-HR**

The Surface Mount Intelligent Strain Gauge Amplifier SMW-HR with an 6 digit 12.7mm, LCD display is a compact microprocessor based unit specifically designed to monitor and control weighing applications. Its flexibility of design allows for the connection of most strain gauges, pressure or strain gauges over a wide range of sensitivity's.

Housed in a light grey, ABS case, it is sealed to IP65 standard to meet most environmental conditions, or as a DIN Rail Mounting module with a separate stainless steel panel mounting display and keypad.

The unit offers the following facilities:-

A simple auto calibration of the highest and lowest weights required, an easy auto tare setting and peak hold facility. A password facility gives protection to setup parameters.

DC analogue outputs of 4-20mA and 0-10V are standard with full scaling over any desired range and the ability to invert these outputs if required.

Two passwords - user and calibrator, 4 point linearisations with multiple strain gauge calibrations stored if required.

Gain sensitivity is selectable via Link & Keypad between 1.25 and 30mV/V.

Several 'plug in' options are available. An optional relay output module provides for 2 set points and hysteresis can be applied to both set points together with In Flight compensation. Relays can be inverted and latched. All these facilities being set digitally in real engineering terms. Both relay and analogue outputs have a high level of isolation.

Optional communications modules provide for 20mA noise immune current loop, RS232 or RS485 connections to a PC, PLC or main frame. This allows for the input variable to be viewed and any setup parameters changed.

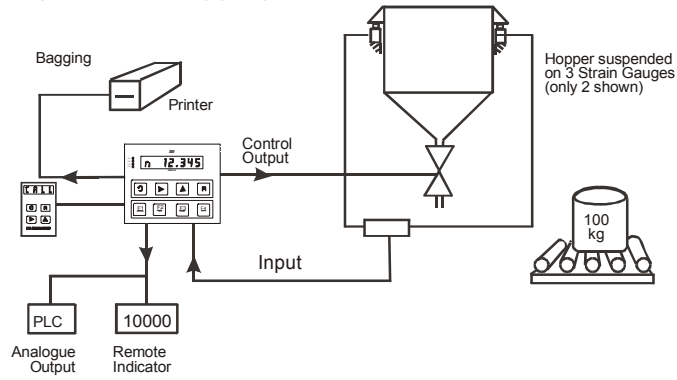
Multiple 20mA SMW-HRs can be connected via an IF25 current loop to RS232 interface which, when included, allows for an expansion of up to 250 SMW-HRs.

The RS232 port is available for Time/Data or data only printers to be used, logging all desired activities.

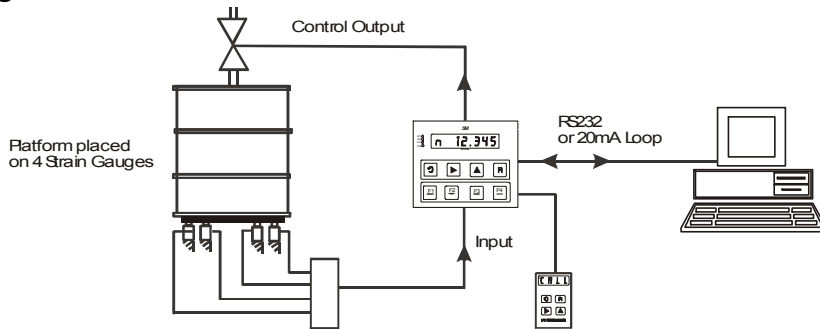
Baud speeds between 300 and 19200 are programmable.

The power supply module is available for 220/240V AC and 110/120V AC or 9-32 and 24/48V DC.

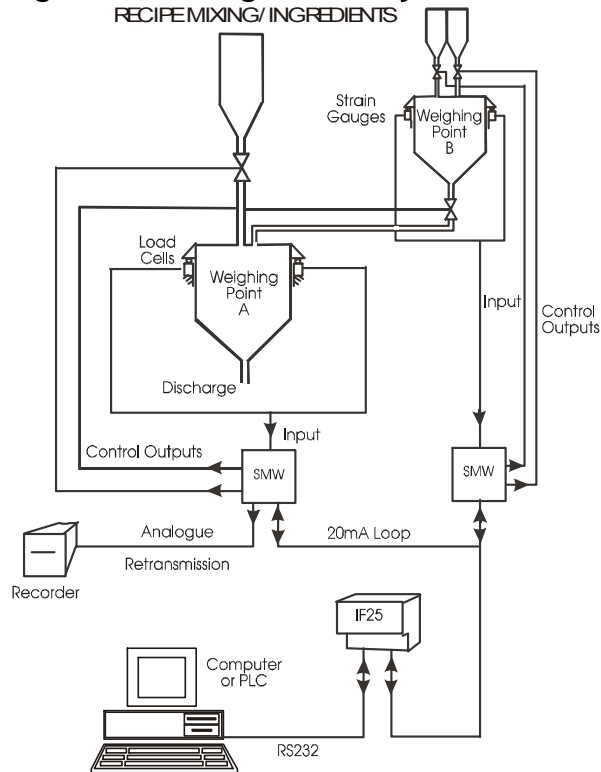
**Figure 1.1 Bagging**



**Figure 1.2 Drum**



**Figure 1.3 Mixing Control by PC**



## Chapter 2 Installing the SMW-HR

In order to maintain compliance with the EMC Directive 2004/108/EC the following installation recommendations should be followed.

**Inputs:** Use individually screened twisted multipair cable. (e.g. FE 585 - 646)  
The pairs should be :  
pins 1 & 6  
pins 2 & 5  
pins 3 & 4  
Terminate all screens at pin 1 of the input. The screens should not be connected at the transducer end of the cables.

**Comms Port:** Use individually screened twisted multipair cable. (e.g. FE 118-2117)  
The pairs should be:  
-Tx & +Tx  
-Rx & +Rx  
Terminate screens at pin 1 of the input .  
The screens should not be connected at the host port.

**Analogue Output:** Use screened twisted pair cable. (e.g. RS 626-4761)  
Terminate screen at pin 1 of the input.  
The screen should not be connected at the host port.

Pin 1 of the input should be connected to a good Earth. The Earth connection should have a cross-sectional area sufficient enough to ensure a low impedance, in order to attenuate RF interference.

### Cable Information (For Reference only)

Country	Supplier	Part No	Description
UK	Farnell	118-2117	Individually shielded twisted multipair cable (7/0.25mm)- 2 pair Tinned copper drain. Individually shielded in polyester tape. Diameter: 4.1mm Capacitance/m: core to core 115 pF & core to shield 203 pF
UK	Farnell	585-646	Individually shielded twisted multipair cable (7/0.25mm)- 3 pair Tinned copper drain. Individually shielded in polyester tape. Diameter: 8.1mm Capacitance/m: core to core 98 pF & core to shield 180 pF
UK	RS	626-4761	Braided shielded twisted multipair cable (7/0.2mm)- 1 pair Miniature- twin -round Diameter: 5.2 mm Capacitance/m: core to core 230 pF & core to shield 215 pF

## ***Environmental Requirements***

SMW-HR units can operate in any industrial environment provided the following limits are not exceeded at the point of installation:

Operating	10 °C to 50 °C
Temperature/Humidity	95 % non condensing
Storage Temperature	-20 °C to +70 °C

Two power supply options are available  
Units can operate from the following:-

220/240V AC, 50/60Hz 10W 110V AC, 50/60Hz 10W	<b>LS1</b>	110/240
9-30V DC, 10W	<b>LS3</b>	(Running current 300 - 530mA Dependent upon module configuration) (start up current - 3Amps for 20mS)

## ***Conditions***

Watts	Power in 12 : 24V	
I. SMW and LP1 with 1 x 350R strain gauge connected, and a 4-20mA analogue output providing 20mA into a short circuit	2.24	2.88
II. With relay module fitted, add	0.58W	0.65W
III. With RS232 module fitted- no device connected, add	0.07W	0.09W
IV. For each additional 350R strain gauge, add	0.38W	0.48W

Note: Maximum number of strain gauges = 6 x 350R or equivalent

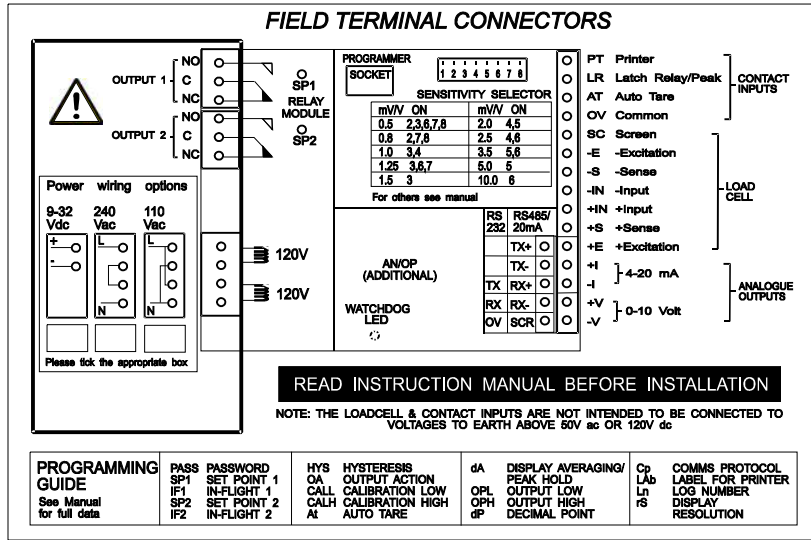
## ***Terminal Connections***

Connection between the SMW-HR unit and input/output signals, including power supplies, are made via 2.5mm field terminal blocks inside the unit.

Access to the terminals is made through glands in the bottom of the case.

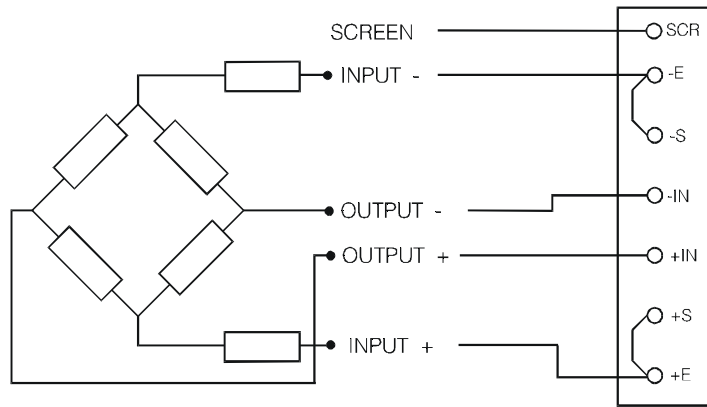
(See Figure 2.1)

**Figure 2.1 The SMW-HR Field Connection Terminals**



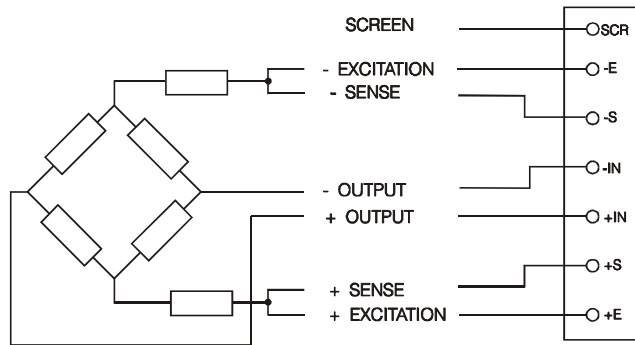
**Figure 2.2 The 6 Wire Strain Gauge**

SMW-HR TERMINAL BLOCK



**Figure 2.3 The 4 Wire Strain Gauge**

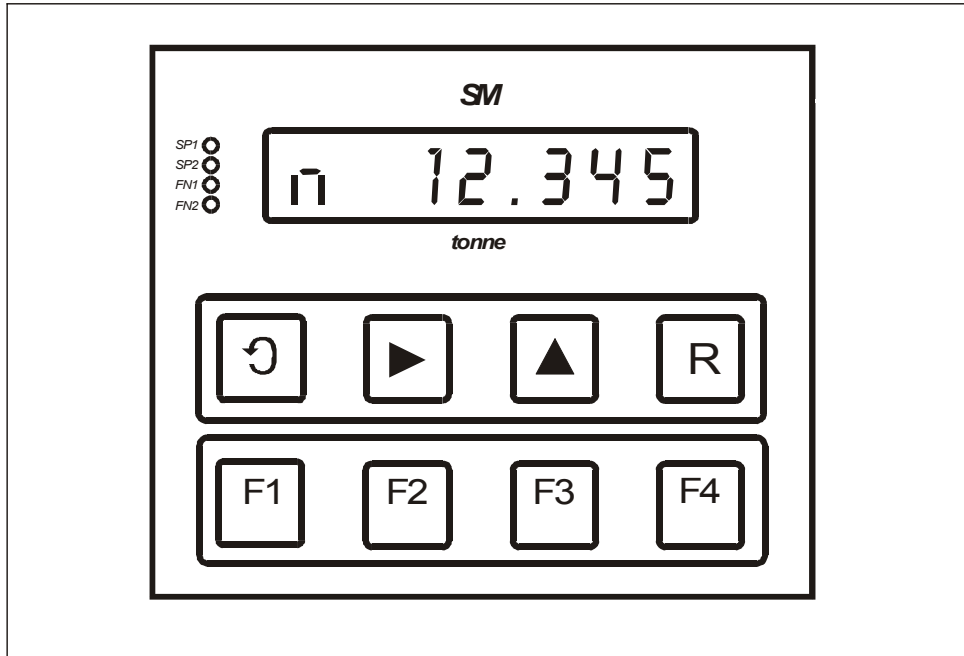
SMW-HR TERMINAL BLOCK












## Chapter 3 The SMW-HR Controls and Parameters

All user controls, displays and indicators are mounted on the front panel which provides a 6 digit, optionally backlit LCD display and 8 flush mounted keys .

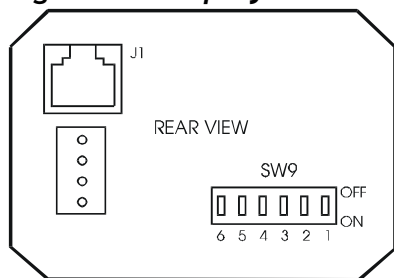
**Figure 3.1 Programmer Unit Panel Layout**



**Table 3.1 Control Panel Guide**

	<p>When in programming mode it should be noted that a flashing -- cursor at the bottom of the selected digit indicates programming mode. Used to scroll through and change the set up data by displaying mnemonics for each configurable parameter, followed by the appropriate data.</p>
	<p>Selects the display digit required. Selection value is indicated by a flashing digit and flashing program cursor -</p>
	<p>Increments each selected display digit 0-9. Pressing the  key under programming conditions will display the leading digit as either minus, or a blank digit for positive values.</p>
	<p>Resets the display to the input variable and enters new data in the SMW-HR memory.  If during the programming sequence, selection is not completed, the display will revert to the input variable after 2 minutes.</p>
	<p>If scale steady then Tare and puts display into Net Mode</p>
	<p>Not Applicable</p>
	<p>Print Function</p>
	<p>Peak Hold Reset</p>
<p>SP1 SP2</p>	<p>Setpoints</p>
<p>FN1&amp; FN2</p>	<p>These are reserved as special function LED's</p>

**Figure 3.2 Display Module Connections and Switch Settings**



POSITION ON	FUNCTION	FACTORY SETTINGS
1	Enables Keys  and	ON
2	Enables <i>all</i> Program Keys &	ON
3	Enables  and  Function Keys	ON
4	Enables  and  Function Keys	ON
5	Not Applicable	OFF
6	Not Applicable	OFF

### The Configurable Parameters

A series of parameters or programmable functions are provided in the SMW-HR to allow the user good flexibility for monitor and control applications.

These parameters are included as constants in the SMW-HR database and are accessed and checked via the programmer keypad or the communications port.

Data which is entered by the user is retained by EEPROM for up to 10 years without back up power.

New data, when entered, overwrites previous entries when the key is pressed unless the EEPROM has been disabled via the communications port.

### Section 1 User/Engineer - Configurable Parameters

#### Password Protection

A 4 digit password number must be entered. The number is accessed when 'PASS' is displayed. At this point, it is necessary to enter Passport number 001111.

Code	Function	Value
trAn	Transducer Number	000000 to 000012
PASS	Setpoint 1	001111
SEtPt1	In-Flight 1	±999999
In-Ft1	Setpoint 2	±999999
SEtPt2	In-flight2	±999999
In-Ft2	Hysteresis for setpoint 1 & 2	±999999
HYS	Latch for setpoint 1 & 2	±999999
LA	CH	000000 to 000003

<b>ACtion</b>	<b>Output action</b>
Bit value 1	invert SETPT1
Bit value 2	invert SETPT2
Bit value 4	invert an-op
Bit value 8	Disp = Gross
Bit value 16	Setpoint = Gross
Bit value 32	An-op = Gross
Bit value 64	Printer = Gross

<b>ACtion</b>	<b>Output action</b>
Bit value 128	Disp = Peak
Bit value 256	Setpoint = Peak
Bit value 512	An-op = Peak
Bit value 1024	Printer = Peak

Peak can be either Gross or Net value by selecting bit value 8 or not.

*Example, peakhold of gross value on display & An-op = 8 + 128 + 512 Peakhold can be reset from 'LR' contact.*

<b>OP LO</b>	Output Low for An-op scaling	±999999
<b>OP Hi</b>	Output high for AN-op scaling	±999999
<b>A-tArE</b>	Auto Tare value	±999999
<b>SCStdY</b>	Not applicable, will default to	000000
<b>rESOL</b>	Display resolution of last digit. This function is performed on the display data only and does not affect the comms or printer	000000 to 000250
<b>CP</b>	Comms Protocol. Selects printer or 'FAST' format. 'CP' = 0 - 127 sets Printer type. 'CP' = 128 sets MANTRABUS communications protocol. See comms and printer section of manual for further details. 'CP' = 130 sets MODBUS Protocol	000000 to 0001300
<b>SdSt/</b>	Sets Serial Device Station Number if 'CP' = 128. This sets a unique address code for each SMW-HR See comms section	000000 to 000254
<b>LAbEL</b>	Sets label for the Printer if 'CP' = 0 - 127. See the printer section	000000 to 000254
<b>Log no</b>	Log Number A range of numbers 0 to 19,999 is available. Any sequential number logging activity can be preset as desired, between these numbers. The number will reset to zero after 19,999. The log number is not saved on power fail and resets to zero on power up.	

## **Section 2 Calibrators - Configurable Parameters**

### **Password Protection**

A 4 digit password number must be entered. The number is accessed when 'PASS' is displayed. At this point, it is necessary to enter Passport number 009999.

Code	Value	Function
trAn	Transducer Number	000000 to 000012
PASS	Security Password	009999
CALL	Calibration Low value for mV/V display. Must be less than CALH. See calibration section.	±999999
CALH	Calibration High value for mV/V display. When CALH is set to zero the SMW-HR will display the raw A/D value of between 0 & 524287. See calibration section.	±999999
AdCALL	A/D Calibration low value for CALL. Must be lower input mV than CALH A/D value. See calibration section	0-524287
AdCALH		0-524287
InPUtA	A/D Calibration high value for CALH. See calibration section	±999999
dISP A	Cal point 1 display value before Lin conversion. See calibration section	±999999
InPUtb	Cal point 1 required display value after Lin conversion. See calibration section	±999999
dISP b	Cal point 2 value for Lin conversion. See calibration section	±999999
	Cal point 2 Display value for Lin conversion. See calibration section	
InPUtC	Cal point 3 value for Lin conversion. See calibration section	±999999
dISP C		±999999
	Cal point 3 Display value for Lin conversion. See calibration section.	
InPUtd		±999999
dISP d	Cal point 4 value for Lin conversion. See calibration section	±999999
dP	Cal point 4 Display value for Lin conversion. See calibration section.	000000 to 000005
	Decimal Point position for currently selected Transducer. The following shows the position of the decimal point	
<b>Code</b>	<b>Position</b>	
000000	999999	
000001	9.99999	
000002	99.9999	
000003	999.999	
000004	9999.99	
000005	99999.9	

<b>A-tArE</b>	Auto Tare value	±999999
<b>SCStdY</b>	Not applicable, will default to	000000
<b>diSP AU</b>	Number of A/D readings taken before the display is updated. This in conjunction with 'FILTER' sets the display update rate	000001 to 000255
<b>rESOL</b>	Display resolution of last digit. This function is performed on the display data only and does not affect the comms or printer	000000 to 000250 000000 to 000002
<b>t-SEnS</b>	Keypad setting of Gain. Used in conjunction with link LK1 on input module to provide the following gains in mV/V, 1.25, 2.5, 5, 7.5, 15 & 30. Note: 't-SEnS' must be set before Auto calibration takes place. See calibration section for more detail	
<b>FILtEr</b>	Sets the A/D sample frequency and notch Filter. This is factory set to 1953 and should not be adjusted. See calibration section.	000019 to 002000
<b>CP</b>	Comms Protocol. Selects printer or 'FAST' format. 'CP' = 0 - 127 sets Printer. 'CP' = 128 sets 'FAST' communications protocol. See comms and printer section of manual for further details 'CP' = 130 sets MODBUS Protocol	000000 to 000130
<b>SdSt/</b>	Sets Serial Device Station Number if 'CP' = 128. This sets a unique address code for each SMW-HR. See comms section.	000000 to 000254
<b>LABEL</b>	Sets label for the Printer if 'CP' = 0 - 127. See the printer section.	000000 to 000254
<b>Log no</b>	Log Number A range of numbers 0 to 19,999 is available. Any sequential number logging activity can be preset as desired, between these numbers. The number will reset to zero after 19,999. The log number is not saved on power fail and resets to zero on power up.	

# Chapter 4 Strain Gauge Input to the SMW-HR

## The Strain Gauge Input

The SMW-HR offers a direct connection to most low level (foil) strain gauge sensors.

A 10 volt excitation is provided and it is monitored to compensate for any variation due to supply drift, Load regulation or voltage drop in the cable between the sensor and the SMW-HR.

The maximum supply current is 150mA which allows for the connection of upto 6 x 350 R Strain gauges.

The SMW-HR's A/D provides 19 bits of resolution (1 in 500,000). The Gain of which can be selected by means of a gain link on the input board (LK1) & by the 't-SEnS' mnemonic. Below is a table showing the relationship between the Gain link & the 't-SEnS' mnemonic.

MV/V INPUT GAIN	LINK LK1	't-SEnS' SETTING
1.25mV/V	Fitted	2
2.5mV/V	Fitted	1
5mV/V	Fitted	0
7.5mV/V	Not Fitted	2
15mV/V	Not Fitted	1
30mV/V	Not Fitted	0

Default setting is gain link fitted with 't-SEnS' set to 1 i.e. 2.5mV/V

The A/D Sample frequency & Notch filter can be set using the 'FILtEr' setting. The A/D can sample at frequencies of 10Hz to 1KHz. The value set in 'FILtEr' is calculated as

$$\text{FILTER} = 19531 / \text{Required sample in Hz}$$

The resolution of the A/D is changed with the value set in 'FILtEr' as outlined in the table below.

Filter	Data o/p rate in Hz & first notch of filter	Resolution in bits	-3db Frequency in Hz
1953	10	19	2.62
781	25	17.5	6.55
390	50	17	13.10
325	60	16.5	15.72
195	100	16	26.20
78	250	12.5	65.50
39	500	10.5	131.00
19	1000	8	262.00

Min value of 'FILtEr' is 19. (Limit of A/D)

This value is Factory Set to 1953 and should not be changed without consulting the factory.

Display update frequency is set by the A/D update rate set in 'FILtEr' & 'dISPAU' which sets the number of A/D readings to be averaged before display and communications ports are updated.

## **Calibration**

Switch on the SMW-HR and allow it to stabilise for 30 minutes to obtain the best performance

*It is important that the gain, set by 't-sens' & LK1, is correct for the strain gauge sensitivity before proceeding with the calibration*

Apply a test weight of about 5% of required operating range to the strain gauges.

Enter the menu using the password from page 3-5, scroll to 'CALL'. Enter programming mode and set 'CALL' value to that of the applied weight. For calibration to be successful program mode must be entered even if 'CALL' has the required value already set. Use the scroll key to move onto 'CALH'.

Apply a test weight of about 80% of required operating range to the Strain gauges.

Enter programming mode and set 'CALH' value for the applied weight. Again program mode must be entered even if 'CALH' has the required value already set.

*For calibration to be successful the 'CALL' calibration weight must be less than the 'CALH' weight.*

Press the **R** key, the calibration constants will now be stored into EEPROM. the display will revert to the live input value which should be that of 'CALH'.

The values for 'ADCALL' and 'ADCALH' are automatically inserted once the auto calibration routine is completed. These values should **NOT** be altered. It is advisable however, to record the values for 'CALL', 'CALH', 'ADCALL' & 'ADCALH' as should these values be lost through operator error they can be re-entered from the keypad without the need of repeating the above procedure.

## **4 Point Linearisation**

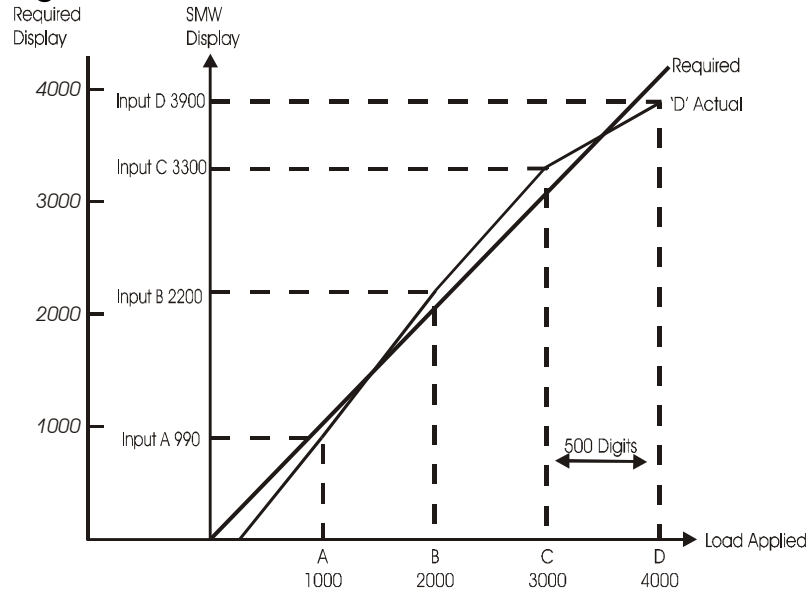
Any non linearity of the system may be reduced by using a 4 point linearisation routine. The 4 points being entered under mnemonics 'InPUt A' to 'dISP d'.

System non-linearity can be determined by plotting a graph of weights applied against display value. 3 straight lines can be applied to this curve, the end of each line providing one of the 4 linearisation points. These are entered as display value for non-linearised 'InPUt' against required 'dISP' value.

Notes on 4 point linearisation (See Figure 4-1)

1. All 4 points must be entered
2. A minimum value of 500 digits between each value must be observed.
3. The line is extended above point 'D' in a straight line set by point 'C' & 'D'
4. The line is extended below point 'A' in a straight line set by point 'A' & 'B'
5. If all 4 points are set to zero then no linearisation is applied.

**Figure 4.1 Internal Linearisation Protocol**



Input = Actual Display before Linearisation

Display = Required display for input value

Input A = 990

Disp A = 1000

Input B = 2200

Disp B = 2000

Input C = 3300

Disp C = 3000

Input D = 3900

Disp D = 4000

## Chapter 5 Analogue Outputs

Two analogue outputs are available offering a DC current range and a DC voltage range.

They are fully scalable, optically isolated and generated from the value as selected under 'Action' mnemonic. The 4 to 20 mA output is precalibrated to an accuracy of within 0.15% of the range. The 0-10V output is accurate to within 2% of the 4 to 20mA output.

Output	Range
DC Voltage	0V to 10V
DC Current	4 to 20mA

Notes:

1. Maximum current load on voltage modules is 2mA
2. Maximum drive voltage available in current modules is 20V

### Output Scaling

Output scaling factors are set by the user and determine the display range over which the analogue module operates.

(OP LO) Output Low - This sets the displayed value at the module's minimum output.

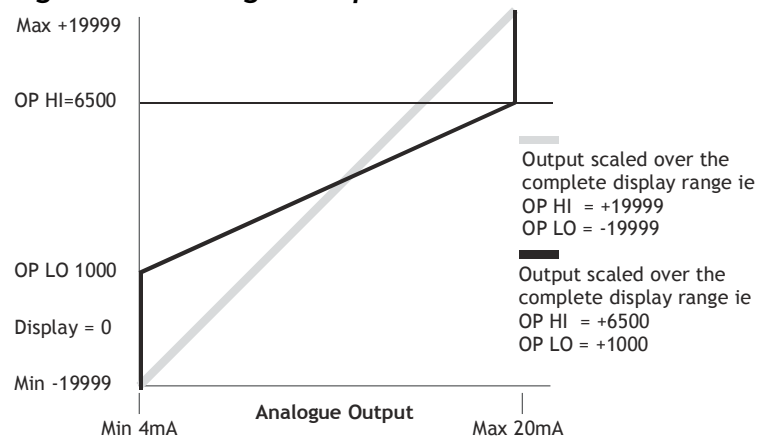
(OP HI) Output High - This sets the displayed value at maximum output. If the display is outside the range defined by OP LO and OP Hi, the analogue output will remain constant at its minimum or maximum output value.

Inversion of the analogue output can be set by the output action mnemonic OA (See Relay Output Module Chapter 6).

Example: Assume a 4-20mA output module is required to provide an output of 4mA for 1000Kg and 20mA for 6500Kg. Set OP LO to 1000 and OP Hi to 6500

It will be necessary to determine OP LO and OP Hi by graphical or mathematical means if the known display values do not coincide with the minimum and/or maximum analogue output.

**Figure 5.1 Analogue Output**



### Method of Calculating OP LO and OP Hi from any known output values

$$OP\ LO = Low\ \frac{-(Display\ span)\ (Low\ output - Min\ output)}{(High\ output - Low\ output)}$$

$$OP\ Hi = High\ \frac{+(Display\ Span)\ (Max\ output - High\ output)}{(High\ output - Low\ output)}$$

Low output = Known low output

High output = Known high output

Min output = Lowest measurable value of output module

Max output = Highest measurable value of output module

Display span = Highest required display value minus lowest required display value.

Example:

Using a 4.20mA output module where it is required to produce 6mA at a display value of 400 and 18mA at a display value of 1100.

$$\text{OP LO} = \frac{400 - ((700)(6 - 4))}{(18 - 6)} = \frac{400 - (1400)}{12}$$

$$\text{OP LO} = 400 - 116.66$$

$$\text{OP LO} = \underline{283.34}$$

$$\text{OP Hi} = \frac{1100 + (700)(20 - 18)}{(18 - 6)} = \frac{1100 + (700 \times 2)}{12}$$

$$\text{OP Hi} = 1100 + 116.66$$

$$\text{OP Hi} = \underline{1216.66}$$

Note 1: OP Hi must be greater than OP LO

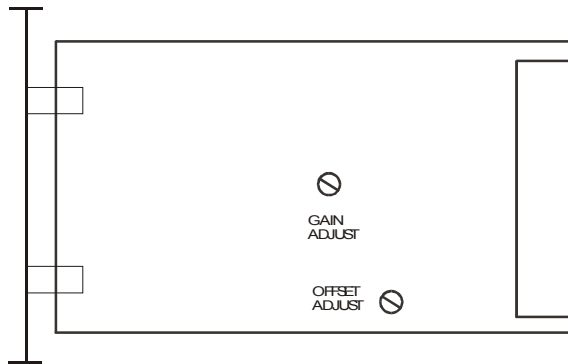
Note 2: If OP LO or OP Hi are greater than  $\pm 19999$  then divide both OP LO and OP Hi by 10, this will give less resolution. Decimal point can be placed anywhere to suit reading.

### **Calibration**

Re calibration can be made by adjusting the gain and offset potentiometers, or by adjusting the values of OP LO and OP Hi.

An offset can be achieved by increasing the values of both OP LO and OP Hi, and the gain by increasing the range between OP LO and OP Hi.

**Figure 5.2 Showing the Potentiometers for Gain and Offset Adjustment**



## Chapter 6 Relay Output Module

### General Description

The Relay output module provides output control signals which can be used for switching functions such as ON/OFF control and alarm indications. The relays are activated by the values programmed for the Set Points. The output configuration will be for open or closed relay contacts and latching.

Output	Function
2 Relays	SPCO on SP1 and SP2

The connections for which are shown in Chapter 2

### Module Functions

The SMW-HR can be programmed so that the relay output module reacts to all or any of the following functions:

- Set points
- In Flight compensation
- Hysteresis
- Relay inversion
- Latching

### Set Points (SP)

Set points are used to produce output signals at any required value so that the operation of the monitored **net** value can be maintained to preset levels. Any excursion beyond set points will activate the relay or relays, to provide alarm or initiate control as required.

Two set points (SP1) and (SP2) can be programmed to suit different applications. The actions of either or both set points can inverted if required.

For normal operation the set point output is active until the input reaches the set point level. In this condition when the input value is less than the set point, the SP indicator is on and the output relay is energized producing a closed circuit on a normally open contact. When the set point value is reached, the SP indicator is off and the relay is de-energized producing an open circuit output.

For an inverted operation the reverse conditions apply.

Normal and inverted action is determined by the direction of the input value as it changes.

For example: In alarm applications.

A High-High operation allows for a rising **net** value to operate on two set points to define an acceptable quantity, weight or band of operation.

A Low-Low operation operates on a falling value.

A High-Low operation will operate on a rising or falling value, setting a 'band' by one set point operating normally and the other being an inverted action.

allowing the In Flight amount to make up the required total set by SP1. A similar situation exists for SP2.

### In Flight Compensation

The setting of an In Flight value causes the set points to automatically adjust to control the flow of the material being weighed.

For example, if SETPT1 is used to control a flow, a certain amount will be 'In Flight' between the supply point and receiving point causing a positive error when the required weight is reached. The In Flight compensation value is adjusted by the user to 'reduce' SETPT1 to prematurely stop the flow, allowing the In Flight amount to make up the required total set by SETPT1. A similar situation exists for SETPT2.

## Hysteresis (HYS)

Once a Hysteresis value has been set, it will be applied to both set points entered. It is effective for both normal and inverted action.

When Hysteresis is applied to set points with normal output action, the input is allowed to rise to the set point value and the output is then turned off. The output is held off until the input value has dropped to the set point minus the Hysteresis value.

For inverted action the input drops to the set point and the output goes off and comes on again when the input rises to the set point plus the Hysteresis value.

## Output Action (Action)

The Output Action facility allows the user to determine whether set points produce normal or inverted output operation. The Output Action (ACTION) is entered by a code to suit the requirements of the user.

11 Output Action options are available.

The value of the ACTION to be entered in the algebraic sum of the following components:-

Bit value 1	invert SETPT1
Bit value 2	invert SETPT2
Bit value 4	invert an-op
Bit value 8	Disp = gross
Bit value 16	Setpoint = gross
Bit value 32	An-op = gross
Bit value 64	Printer = gross
Bit value 128	Disp = Peak
Bit value 256	Setpoint = Peak
Bit value 512	An-op = Peak
Bit value 1024	Printer = Peak

Peak can be either Gross or Net value by selecting bit value 8 or not.

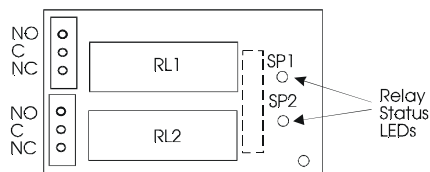
*Example, peakhold of gross value on display & An-op = 8 + 128 + 512 Peakhold can be reset from 'LR' contact.*

## Latching Outputs (LAtCH)

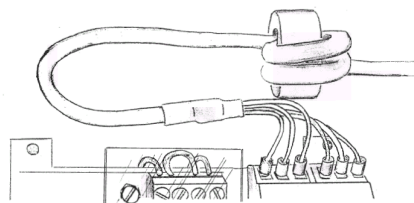
The latching facility allows the relay module output to be held until reset either by keypad, external remote or via the communications port. Latching is applied to the off status of the relay SETPT1 or SETPT2.

SETPT1	SETPT2	Code
Unlatched	Unlatched	0
Latched	Unlatched	1
Unlatched	Latched	2
Latched	Latched	3

**Figure 6.1 LR1 Module**



**Figure 6.2 Installation of LR1**



To meet the Specified EMC Fast transient requirements it is important that the ferrite ring supplied is fitted as per the following instructions.

Illustration showing ferrite ring FEC 323-4940 fitted to the LR1 relay wiring.

Two turns of the wiring are passed through the ring positioned 12cm from the LR1 end of the cable to improve immunity to electrical fast transients and bursts.

# Chapter 7 The Communications Port

## Introduction

The SWM-HR communications port provides for a 2 way data link. An intelligent host e.g. Personal Computer, Main Frame or PLC is able to acquire the SWM-HR's displayed value and read or modify the user configurable parameters, using any of the following:-

- a) RS232/485 - for a one to one communication (as in the case of a printer, PC or PLC).
- b) RS485 - for the connection of up to 25, SWM-HR units on a single RS485 line.
- c) 20mA Current Loop - for up to 250, SWM-HR units on a single RS232/485 line, via the IF25 interface. With high noise immunity and isolation over distances up to 1Km.

4 communication formats, MANTRABUS, ASCII, MODBUS RTU and PRINTER, are selected from the mnemonic CP via the keypad, of the programmer.

Integrity is ensured by pre-programmed default parameters should a loss of communications with the host occur.

## Serial Communication Protocol

### General

Incoming data is continually monitored by the SWM-HR on its serial input line.

Each byte of data is formatted as an eight bit word without parity, preceded by one start bit and followed by one stop bit.

Transmission and reception of data up to 19.2K Baud is possible, the actual rate being selected by an 6 way link on the communications module. The Baud rate depends upon the communications, hardware specification, distance and cable type.

See Comms for Baud Link settings. Chapter 7

### **MANTRABUS Format - selected when CP is 128**

To signify commencement of a new 'block' of data, the HEX number FFH is used as a 'frame' character, followed by the station number of the unit under interrogation. This is entered via the SWM-HR keypad under mnemonic SDSt and ranges from 0-254).

The SWM-HR acts upon incoming data only if its own station number immediately follows the FFH character.

New data must be received as a string of four nibbles (bits 7-4 set to zero) which are assembled into two bytes and written into the variables store within the SWM-HR. The most significant nibble must be received first and the last nibble must have the most significant bit (bit 7) set to indicate the end of data. This is followed by the checksum. The data transmitted from the SWM-HR is always sent as complete bytes. The station number precedes the data and the checksum follows the data. The data format used is signed 15 Bit. The most significant Bit of the most significant Byte is set for negative numbers.

### Operation

There are two modes of operation, namely data requests by the host controller and data changes. Data requests from the SWM-HR consist of either a complete dump of the data variables stores in RAM or the display reading. Data changes consist of writing new data to SWM-HR variables, thus changing parameters such as Set Points, in flights etc.

An acknowledgement message is returned to the SWM-HR to indicate that the new data has been acted upon.

### Updating

The required mode or variable to be updated is determined by the station number followed by the command byte. An EXOR checksum consisting of the station number command byte and any following data must be appended to the received data. It is most important that the byte proceeding the checksum must have its most significant bit set to signify the end of data.

The SWM-HR works out its own checksum and, if it disagrees with the received one, a Not Acknowledge (NAK) message is returned.

## **Communications Commands**

The following is a list of commands available for reading to or writing from the SWM-HR.

<b>Command No.</b>	<b>Description</b>
1	Data dump including Gross & Net values
2	Returns Gross & Net values
3	Spare
4	Write to channel number (sets current transducer)
5	Write to SETPT1
6	Write to IN-FT1
7	Write to SETPT2
8	Write to IN-FT2
9	Write to HYST
10	Write to LATCH
11	Write to ACTION
12	Write to OP LO
13	Write to OP Hi
14	Write to CALL
15	Write to CALH
16	Write to ADCALL
17	Write to ADCALH
18	Write to CAL1 I
19	Write to CAL1 d
20	Write to CAL2 I
21	Write to CAL2 d
22	Write to CAL3 I
23	Write to CAL3 d
24	Write to CAL4 I
25	Write to CAL4 d
26	Write to DP
27	Write to A-TARE
28	Write to SCSTDY
29	Write to DISPAV
30	Write to RESOL
31	Write to TSENS
32	Write to FILTER
33	Write to CP
34	Write to SDST
100	Request AUTOTARE
101	Request RELAY RESET
102	Reset PEAK HOLD
103	Reset TARE VALUE TO ZERO
104	Set display to GROSS
105	Set display to NET
106	Disable EEPROM
107	Enable EEPROM & READ TO IT
108	Enable EEPROM & WRITE TO IT
109	Disable KEYPAD
110	Enable KEYPAD
111	Set A/D

### **Command 1 Request for all data:**

DATA TRANSMITTED TO SMW-HR FOR COMMAND 1  
0FFH, Station Number, 081H, Chksum

Where Chksum = Station number EXOR with 081H.

Command 1 Request for all data: DATA TRANSMITTED TO SMW-HR FOR COMMAND 1

0FFH, Station Number, 081H, Chksum

Where Chksum = Station number EXOR with 081H.

Example: To obtain a complete dump of the variables in the SMW whose Station number is 47 send the following Data:-

0FFH, 02FH, 081H, 0AEH

    |  
    Note MS Bit Set

### ***Response to Command 1***

#### **Bytes**

1	SDST
2, 5	Gross Value
6-9	Net Value
10	Status Flag
11-14	tRAN/CHANNEL
15-18	PASS
19-22	SETPT1
23-26	IN-FT1
27-30	SETPT2
31-34	IN-FT2
35-38	HYST
39-42	LATCH
43-46	ACTION
47-50	OP LO
51-54	OP HI
55-58	CALL
59-62	CALH
63-66	ADCALL
67-70	ADCALH
71-74	INPUTA
75-78	DISP A
79-82	INPUT B
83-86	DISP B
87-90	INPUT C
91-94	DISP C
95-98	INPUT D
99-102	DISP D
103-106	Dp
107-110	A-TARE
111-114	SCSTDY
115-118	DISPAV
119-122	RESOL
123-126	TSENS
127-130	FILTER
131-134	CP
135-138	SDST
139-142	LOG NUMBER
143	EEPROM STATUS
144	EX-OR CHEKSUM

## COMMAND 2 REQUEST DISPLAY DATA

DATA transmitted to SMW-HR for Command 2.

0FFH, Station number, 082H, Chksum

Where Chksum = Station number EXOR with 082H

Example: To obtain the display reading of an SMW-HR whose station number is 47 send the following Data:  
0FFH, 02FH, 082H, 0ADH

                  |  
                  Note MS Bit Set

### Response to Command 2

Bytes

1	SDST
2, 5	GROSS VALUE
6-9	NET VALUE
10	STATUS FLAG
11	DECIMAL POSITION
12	EX-OR CHECKSUM

STATUS FLAG

Bit	Flag
0	RELAY 1 ON
1	RELAY 2 ON
2	NOT USED
3	NOT USED
4	NOT USED
5	NOT USED
6	SCALE STEADY
7	GROSS/NET DISPLAY SELECTED

### COMMANDS 4 TO 34: Write data to SMW-HR Parameter

Commands 4 to 34 all have the same format.

Format for data transmitted to SMW-HR for Commands 4 to 22:-

0FFH, Station No, Command No, MSN, NIB7, NIB6, NIB5, NIB4, NIB2, LSN, CHKSUM

Where MSN = Most significant nibble of data

NIB7-2 = Nibble of data between MSN and LSN

LSN = Least significant nibble of data with MSBIT set

CHKSUM = The following EXOR'd with each other, Station number, command number, MSN, NIB7-2, LSN with MSBIT set

Example: To change Dp to 3 on a SMW-HR whose station number is 47. The following data is sent.

0FFH,02FH,00FH,00,00,00,00,00,00,00,83H, 0A3H

                  |  
                  Note MSBIT set

### Response to COMMAND 4 to 34

If the data has been accepted by the SMW-HR then the following acknowledgement string is transmitted by the SMW-HR.

Station number, 06H (ACK)

If there are any errors with the data received by the SMW-HR then the following

Not Acknowledgement (NAK) string is transmitted by the SMW-HR:-

Station number, 015H (NAK)

### Commands 100 onwards

These commands perform action and require only the command number to be transmitted to the SMW-HR i.e. To disable the keypad of device 47 using command 105 the following data is sent

```
OFFH,2FH,E9H,C6H
      |
      v
    MS BIT SET
```

These commands will be acknowledged by an 'ACK' or if an error a 'NAK' proceeded by the station number.

#### Example of a Basic Code to Communicate with MANTRABUS

open the serial port with no handshaking

```
OPEN"COM2:4800,N,8,1,RS,DS,BIN" FOR RANDOM AS#1
```

request display from device 1

Frame FF	Station No	Command 2	Checksum of
	1	and add 80 hex to this byte as it is the last before as the checksum	all bytes except frame

```
talk$=CHR$(&HFF)+CHR$(&H1)+CHR$(&H82)+CHR$(&H1 XOR&H82)
```

*print the string to the port*

```
PRINT#1,talk$;
```

*(must add semicolon after string to stop transmitting a carriage return)*

*wait for a while (this depends on how many bytes you are expecting and the baud rate!)*

*input all the bytes in the serial buffer*

```
input.from.smw-hr$=INPUT$(LOC(1),#1)
```

## MODBUS Protocol

This modbus protocol has been implemented in accordance with:-  
Modicom MODBUS Protocol Reference Guide P1 - MBUS - 300 Rev.C  
The following conditions apply:-

Baud Rate must be set to 9600

The format is RTU

Data transfer is considered to be Half Duplex, using 2 or 4 wire RS485 medium.

UART's shall be set for 8 bit word , 1 start bit , 1 stop bit & no parity

## MODBUS IMPLEMENTATION FOR HIGH RESOLUTION - CP = 130

### Commands

The command used for reading of the SMW-HR shall be command 03, READ OUTPUT REGISTER. The SMW-HR data, including display & programmable parameters, shall be considered to be 32 bit "Holding registers" accessed as two 16 bit words. Data format will be signed 31 bit with the MS bit of the MS byte being the polarity.

The command for writing data & performing "actions" shall be command 16, PRESET MULTIPLE REGISTERS. All write commands must be 2 register bytes long. Multiple writing to 32 bit registers is therefore not allowed.

A processing time for The SMW-HR communications software has been estimated at 6mS.

Note:- 'Broadcast' messages Using address 0 is **NOT SUPPORTED**

### Exception Responses

The following exception codes will be used only,

- 01 Illegal function
- 02 Illegal data address
- 03 Illegal value

These codes have been indicated as the minimum error handling system required Modicom. A fault log shall not be implemented by the SMW-HR

### **Register Allocation**

Register shall be allocated the following values. Odd values are used as a register is only 16 bits & data will be read as 32 bits. For action commands data is ignored but again 2 registers must be written to. See examples.

40001	GROSS DISPLAY VALUE
40003	NET DISPLAY VALUE
40005	STATUS BYTE. INCLUDES SETPOINT STATUS, EEPROM (More Detail To Follow) DUMMY for continuity only
40007	CHAN
40009	PASS
40011	SETPT1
40013	IN-FT1
40015	SETPT2
40017	IIN-FT2
40019	HYST
40021	LATCH
40023	ACTION
40025	OP LO
40027	OP HI
40029	ACALL
40031	ACALH
40033	ADCALL
40035	ADCALH
40037	DTP1I
40039	DTP1D
40041	DTP2I
40043	DTP2D
40045	DTP3I
40047	DTP3D
40049	DTP4I
40051	DTP4D
40053	DPSEL
40055	DISZER
40057	SCALES
40059	AVRGE
40061	RESOL
40063	GAIN
40065	FILTER
40067	CP
40069	SDST
40071	LOGNUM LOG NUMBER printer only
40073	

### **Action commands**

40101	DO AUTOTARE
40103	DO LATCH RELAY RESET
40105	DO PEAK HOLD RESET
40107	RESET TARE VALUE TO ZERO
40109	SET DISPLAY TO GROSS
40111	SET DISPLAY TO NET
40113	DISABLE EEPROM
40115	ENABLE EEPROM & READ DATA FROM IT INTO RAM
40117	ENABLE EEPROM & WRITE DATA IN RAM TO IT
40119	DISABLE KEYPAD
40121	ENABLE KEYPAD
40123	RECONFIGURE A/D AFTER WRITE TO GAIN OR FILTER

## Examples

The following are examples of the commands. Channel 1 has been used for examples

### Read NET value from Channel 1

Data sent from PLC

01 03 9C 43 00 02 1B 8F

Data sent from SMW-HR

01 03 9C 43 00 02 ,MSB, NMSB, NLSB, LSB, CRC-16 HI, CRC-16 LO

### Auto-Tare Channel 1

Data sent from PLC

01 10 9C A5 00 02 04, xx, xx, xx, xx, CRC-16 HI, CRC-16 LO

Where xx = Don't care

Data sent from SMW-HR

01 10 9C A5 00 02 CRC-16 HI, CRC-16 LO

### Set Setpoint 1 on Channel 1

Data sent from PLC

01 10 9C 4D 00 02 D1, D2, D3, D4, CRC-16 HI, CRC-16 LO

Where D1 = data MSB, D2 = data NMSB, D3 = data NLSB, D4 = data LSB

Data sent from SMW-HR

01 10 9C 4D 00 02 CRC-16 HI, CRC-16 LO

### A note about EEPROM

All user set parameters are stored in EEPROM where they are recalled on power up. The EEPROM has a limited number of write cycles of between 10,000 & 1,000,000. If setpoint data is to be written to the SMW-HR we suggest disabling the EEPROM from the comms using register 40113. This register is written to with no data as the Auto-tare command.

### Disable EEPROM on Channel 1

Data sent from PLC

01 10 9C B1 00 02 04, xx, xx, xx, xx, CRC-16 HI, CRC-16 LO

Where xx = Don't care

Data sent from SMW-HR

01 10 9C B1 00 02 CRC-16 HI, CRC-16 LO

## ASCII Protocol

### Host Transmission

The command structure is based on the following format

Framing Character	Address	Separator	Command	Response	Data	End of frame
!	001	:	CALH	=	-99.9999	<CR>

For example !001:SP1=123.456<CR>

An explanation of each field is as follows.

**Framing character:** A single “!” is used to “frame up” the receiving devices allowing all instruments to see the start of a new message. The “!” character will only be transmitted by the host for framing purposes

**Address:** The Address is always 3 ASCII characters representing the devices to which the command is intended. Address 999 is reserved for Broadcast addressing for which there is no response.

**Separator:** Must always be sent by host. As no Checksum or message verification technique is used this separator character is a further check by the instrument on the incoming message.

**Command:** Up to 6 alpha-numeric characters can be used in this field. The mnemonic approach has been used as this would be intended to be as the mnemonics will appear to the user from the 7 segment display thus saving the user remembering a command list. Upper and lower case can be used within field as no discrimination is made.

**Response:** Defines what sort of response is expected. If a “=” appears here then data is expected to follow. If a “?” is received then the host is expecting data back from the instrument. If nothing is received then the command is expected to be an action type i.e. Tare, relay reset. In all cases the instrument will respond with data (see Instrument response) except when the address is 999 which is a general broadcast address.

**Data:** This field can include any printable ASCII characters except “!”. A maximum string length of 40 characters will apply to this field. The field will be decoded by a command specific routine in the instrument. This open approach allows good flexibility for the data into the instrument which could include modem strings Pass words etc. etc.

**End of frame:** A <CR> must always transmitted to indicate end of frame & it will be from this point that the data will be decoded from the instruments receive buffer & acted upon

There are 3 basic command types, command read which are used to read data from an instrument, command write which writes data into the instruments & action commands which perform an instrument function such as tare or EEPROM disable. The following are examples of the 3 types.

#### Command Read

Framing Character	Address	Separator	Command	Response	Data	End of frame
!	001	:	disp	?		<CR>

#### Command Write

Framing Character	Address	Separator	Command	Response	Data	End of frame
!	001	:	RESOL	=	0.10	<CR>

#### Command Action

Framing Character	Address	Separator	Command	Response	Data	End of frame
!	001	:	RESREL			<CR>

### Response from Instruments

A response from the instrument is always sent, the only exception being when a “broadcast” command is issued. Broadcast commands will only be accepted for Action & write commands. The responses are as follows :-

#### Command read.

Returns the requested value specified by the command. The length of the alpha-numeric data is not fixed (max. length will be 40 characters). Returned data will be terminated with a <CR>. Examples of returned data are as follows.

2.34<CR>

-56.78<CR>

1999.99<CR>

GEORGE<CR>

If the Command is not understood by the instrument then a “?” is transmitted followed by a <CR> is sent by the instrument.

**Command write.**

If the command & value is accepted by the instrument then a <CR> is transmitted, if not accepted a “?” followed by a <CR> is sent.

**Command action.**

If the command is accepted by the instrument then a <CR> is transmitted, if not accepted a “?” followed by a <CR> is sent.

**Response timing.**

From receipt of the host’s terminating <CR> to a response from the instrument is expected to be within 50mS.

**Continuous output stream**

By sending an “XON” the instrument will transmit it’s display value every display update until an “XOFF” or framing character is received. The display value can be selected under the “Action” mnemonic. This MUST only be used in a 1 to 1 system.

**Response timing.**

From receipt of the host’s terminating <CR> to a response from the instrument is expected to be within 50mS.

**Continuous output stream**

By sending an “XON” the instrument will transmit it’s display value every display update until an “XOFF” or framing character is received. The display value can be selected under the “Action” mnemonic. This MUST only be used in a 1 to 1 system.

## **List of commands**

GROSS	Current gross value. Read only
NET	Current net value. Read only
STATUS	Current Status flag. read only
TRAN	Transducer selected . Power on default = 0
PASS	Read only
SETPT1	Setpoint 1
IN-FT1	In-flight 1
SETPT2	Setpoint 2
IN-FT2	In-flight 2
HYST	Hysteresis for setpoint 1 & 2
LATCH	Latch for setpoint 1 & 2
ACTION	Output action
OPLOW	Output Low for An-op scaling
OP HIGH	Output high for An-op scaling
CALL	Calibration low point
CALH	Calibration high point
ADCALL	A/D value for low calibration point
ADCALH	A/D value for high calibration point
INPUTA	4 point linearisation input value A
DISP A	4 point linearisation display value A
INPUTB	4 point linearisation input value B
DISP B	4 point linearisation display value B
INPUTC	4 point linearisation input value C
DISP C	4 point linearisation display value C
INPUTD	4 point linearisation input value D
DISP D	4 point linearisation display value D
DP	decimal point position
A-TARE	Auto-Tare value
SCSTDY	Scale steady value which must be held for 2 seconds Unit will not Auto tare til scale steady. Can be disabled with value of 0
DISPAV	Display averaging
RESOL	Display resolution
T-SENS	A/D gain
FILTER	A/D filtering
CP	Comms protocol. Read only
SDST	Serial device station number or Label for printer. Read only
LOGNUM	Incremental log number for printer. reset to 0 on power up

## **Action commands**

DOTARE	Perform Auto-Tare
RESREL	Reset Latch relays
RESPH	Reset Peak hold
RESTAR	Reset Tare value to zero
SETGRS	Set display to Gross value
SETNET	Set display to Net value
DISE2R	Disable E2rom
ENE2RR	Enable E2rom & read from it
ENE2RW	Enable E2rom & write RAM to it
DISKEY	Disable Keys
ENKEY	Enable keys
SETAD	Reset A/D using filter & t-sens values
HELLO	Used to determine if device present. Returns CR

## SMW-HR Printer Interface

(CP must be set between 0 - 127) Dependant on printer type

Printer selection enables the SMW-HR to print its current display value to a printer via its communications port. This display value can either be assigned a date and time stamp. A label can be suffixed to the printed display value using the mnemonic 'Label'. A large range of labels are available to the user. (See table below.)

'Label' Value	Label	'Label' Value	Label
1	mV/V	17	psig
2	kN	18	psia
3	N	19	Pa
4	MN	20	kPa
5	kgf	21	MPa
6	gf	22	kp
7	daN	23	kpm
8	lbf	24	kgfm
9	tonf	25	Nm
10	UStonf	26	kNm
11	ozf	27	MNm
12	g	28	lbf ft
13	t	29	lbf in
14	kg	30	oz in
15	bar	31	mm
16	mbar		

The time and date are set in the TDP printer itself using its own menu. The printer allows the entry of an additional custom text message.

Three connections are required between the SMW-HR communications port and the printer with a maximum cable length of 100 metres.

### Additional Mnemonics for the Printer Operation:

- CP At this mnemonic the printer type and print format number is selected. This number being appropriate to the type of printer used. Details are advised with each type of printer selected.  
Present types available are:- For the ITT IPP-144-40E printer the following numbers apply
- 0 Prints a sequential log number with the current display and unit of measure  
e.g. **00014 0011.3 tonne**
- 1 Prints date and time with a sequential log number, current display and unit of measure  
e.g. **00015 0001.7 tonne**  
**22.05.07 05:06**
- 2 Prints a sequential log number, current display, unit of measure with customer text message No 1  
e.g. **MANTRACOURT ELECTRONICS SMW-HR PRINTER**  
**00012 000.2 tonne**
- 3 Prints date and time with a sequential log number, current display, unit of measure and a customer text message No.1  
e.g. **MANTRACOURT ELECTRONICS SMW-HR PRINTER**  
**00013 0023.6 tonne**  
**22.05.07 12:03:04**

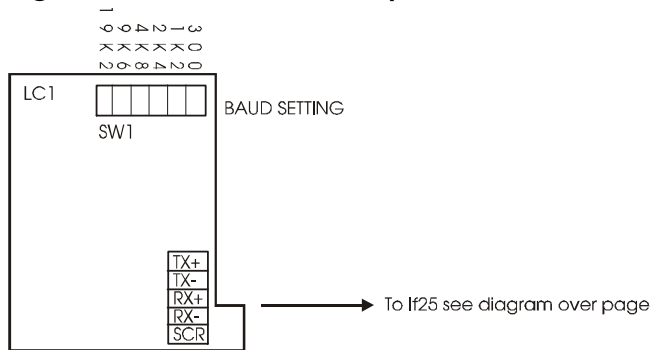
- 4-7 Digitec 6700 series. As ITT Printer 0-4
- 8,9 Amplicon AP24 and AP40 (9 inverts Text)
- 10 Eltron LP2142 - (The label file must be called 'MEL' and the label must contain a LOG NUMBER, THE DISPLAY VARIABLE & a LABEL (not zero).
- 12 ASCII string on print command

Provision is made in the SMW for communications via one of two module options:

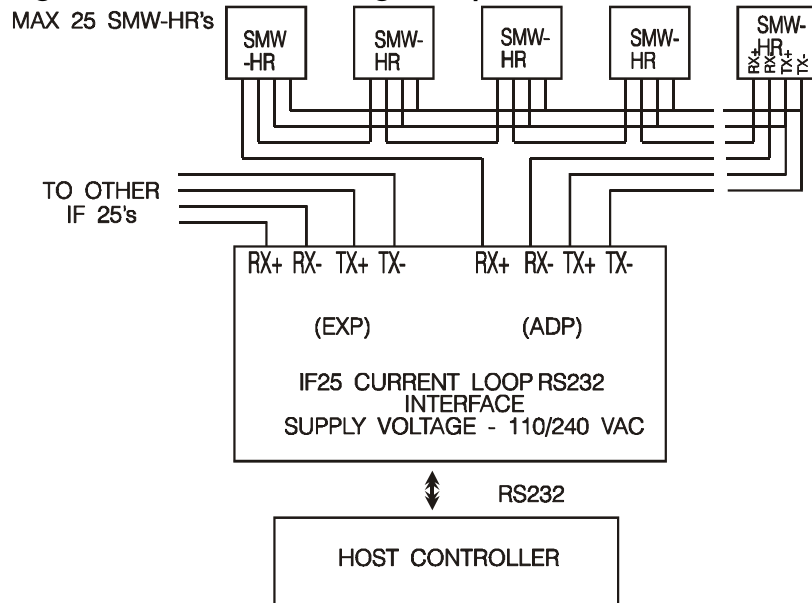
- LC1 The 20mA current loop module, for connection to an IF25 interface.
- LC3 An RS232/485 isolated module, for connection to a PC or PLC, in a single or multiple function

Connections for these options are shown:-

**Figure 7.1 LC1 Current Loop**



**Figure 7.2 IF25 Connecting Multiple SMW-HRs**



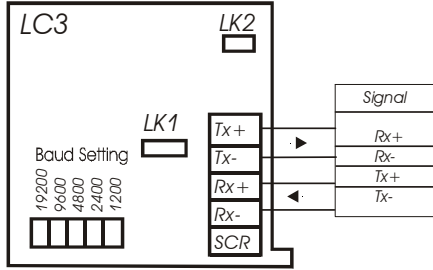
Connecting Multiple SMW-HR to the IF25 Interface

Notes

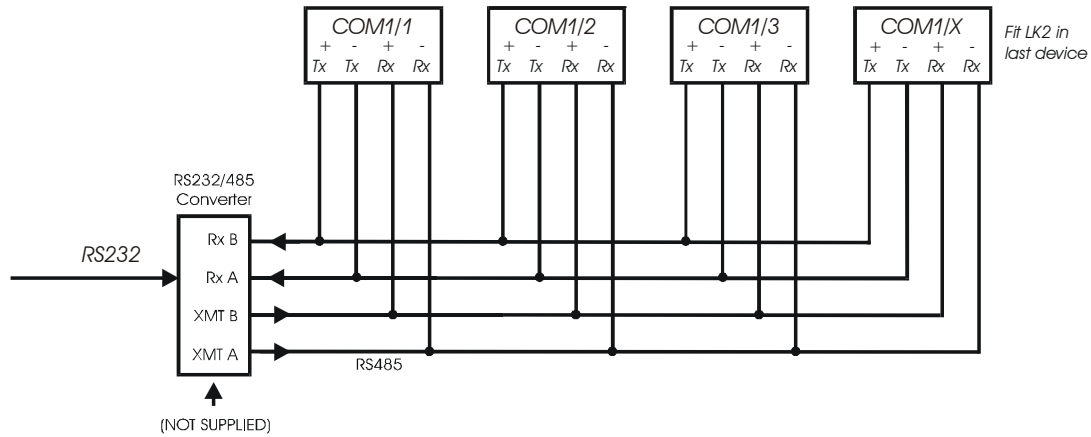
- 1. Maximum loop voltage is 50V dc.
- 2. Loop is isolated from host and SMW-HR. Loop should be earthed via Rx - on IF25/254
- 3. IF25 used for up to 25 SMW.
- 4. At 19,200 Baud, max.cable length is 100m metres, using cable type BICC H8085.

**Figure 7.3 LC3 Isolated RS232/485-Mode Connections**

Note: LK2 when multi dropping RS485, the last device should be terminated with 120R

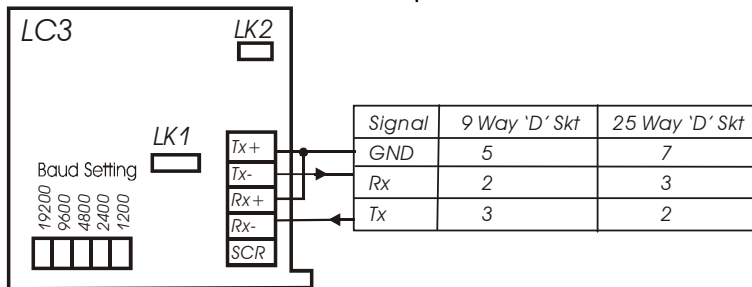


**Figure 7.4 Connecting Multiple Units on RS485**



**Figure 7.5 LC3 RS232 Mode Connection to PC**

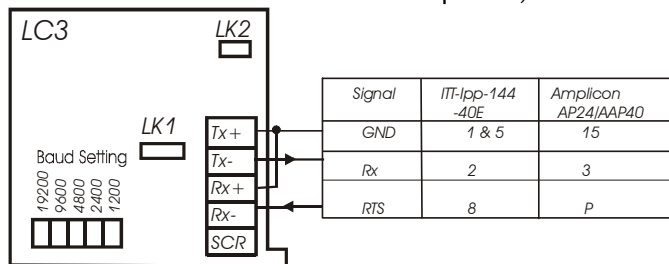
Note: LK1 must be made for RS232 operation



### Figure 7.6 LC3 RS232 Mode Connection to Printer

Note 1: LK1 must be made for RS232 operation

Note 2: If no RTS is available from the printer, fit LK2



#### NOTE :

When using an RS232 to RS485 converter which has a non-biased receiver, the following actions are recommended:-

To bias the device:

1. Terminate the receiver with 140R in place of the usual 120R
2. Fit a 1.5K from the receive negative to the receiver +5V supply, or a 3K3 to the +12V supply.
3. Fit a 1.5K from the receive positive to the receiver supply Ground.

## Chapter 8 Trouble Shooting Guide

This chapter is designed to assist in the identification of problems relating to the installation and setting up of the SMW-HR.

### 1. General Connection and setup parameters. No display on power up.

- a) Check supply is present at the SMW-HR terminals.
- b) If supply is correct contact Mantracourt.

### Display shows (-1 or 1) continually, without a weight applied to the strain gauge.

- a) Check input connections to the SMW-HR from the strain gauge.
- b) If connecting a 4 wire device ensure terminals 1&2 and 5&6 are linked.
- c) Check strain gauge output between input terminals 3&4 of the SMW.
- d) Check that the CALH weight is applied and is not the same or lower than CALL.

### Display over ranges (-1 or 1) when, or before, the maximum required weight is applied to the strain gauge.

- a) Check output of strain gauge is set to the correct sensitivity settings on the DIL switches

### Display very noisy

- a) If using a 4 wire device ensure terminals 1&2 & 5&6 are linked.
- b) Check output voltage of strain gauge.

### Display operating in wrong direction

- a) Check connections to input terminals 3&4 are correct way round.
- b) Check the type of strain gauge - compression or tension.

### Unit will not auto calibrate

- a) Check that CALH is not zero and its weight is greater than CALL.
- b) Check that input is not overranged on CALH weight.

### Unit will not Auto Tare

- a) Check DP r code for correct setting.
- b) Check auto tare sequence, when selected from keypad, is completed within 1 second.

### Access to parameters not possible beyond the PASSWORD (PASS)

- a) Check for special password if not (1111) with your company or supplier. (Quote serial number as a reference.)

### 2. Relay Output Module - Incorrect Relay Operation

- a) Check set point, in flight and hysteresis values are correct.
- b) Check latching and inversion settings in output action (OA) are correct.
- c) Check connections to output terminals.

### Remote function (Auto Tare, Peak Hold / Latched , printer fails to operate)

- a) Check 'DP-r' for correct value to ensure desired function selected.

### 3. MANTRABUS / ASCII Format. No Communications

- a) Check that a comms module is fitted.
- b) Check correct CP code is entered for required protocol.
- c) Check connections to SMW from IF25 are correct.
- d) Check IF25 green LEDs are on and RX LED is on and TX LED is off.  
Press TX TEST , TX LED should light.
- e) Check RS232 connections from the host to the IF25 are correct.
- f) Check SdSt, serial device station number is correct.
- g) Check Baud rate settings on SMW's are correct for the host.
- h) Check host comms port is set to 8 bit word, 1 start bit, 1 stop bit, no parity.
- i) Check correct protocol is being observed by the host.
- j) Check if using ASCII a null character is being sent by host for each Byte expected back.

## Chapter 9 SMW-HR Specifications

### Strain Gauge Input

<b>Calibration</b>	Automatic digital by use of keypad and 1 (or 2) known weights giving $\pm 0.0015\%$ linearity
<b>Initial Calibration</b>	Linear mV/V input, using auto-cal giving $\pm 0.0015\%$ linearity
<b>SI Units/Linearisation</b>	4 point linearisation and conversion of mV/V value into engineering units. Optional facility to download mV/V value to a Computer for conversion using a third order polynomial equation.
<b>Auto Tare</b>	Auto Tare values can also be viewed and manually changed if required. Auto tare value is retained on power down. Auto Tare is affected from the field terminals.
<b>Input Sensitivity Range</b>	1.25mV/V to 30m V/V (selectable ranges $\pm 1.25, 2.5, 5, 7.5, 15, 30\text{mV/V}$ )
<b>Zero Temperature Coefficient</b>	$< 0.0005\%$ FSO/ $^{\circ}\text{C}$ typical with 2.5 mV/V sensitivity selected
<b>Span Temperature Coefficient</b>	$< 0.0017\%$ reading / $^{\circ}\text{C}$ ( $< 0.0007\%$ reading / $^{\circ}\text{C}$ Typical)
<b>Excitation</b>	9.6V DC nominal, 160mA maximum
<b>Compensation</b>	By $\pm$ sense wires to compensate for cable, connection
<b>Repeatability</b>	$< \pm 0.002\%$ reading over 90 days
<b>Display Update Rate</b>	Programmer keypad selectable between 0.1 and 25.5 seconds
<b>Display Average</b>	Set by programmer keypad, up to 64 standard updates
<b>Display Resolution</b>	1:500,000

### DC Analogue Outputs

Range	MIN	MAX	Max Drive Capability	Typical Accuracy % of reading	% of FSD
+4		+20mA	20V (1K)	$\pm 0.08\%$	$\pm 0.08\%$
0		+10V	2mA	$\pm 0.08\%$	$\pm 0.08\%$
Isolation:		$\pm 130\text{V}$ RMS or DC to any other port			

### Control / Alarm Relay Output (RR1)

2 SPCO relays, SETPT1 and SETPT2  
Contact Rating 50V @ 500mA AC

Setpoint, In Flight Compensation, Hysteresis, Latching and Relay Inversion are set digitally using programmer keypad and display, in engineering units.

Hysteresis value applies to both SETPT1 and SETPT2. (Fail safe operation by setting inversion to give normally energised operation).

Latching Reset By volt free contact to field terminals or by communication

## ***The Communications Port Data***

### **Operation**

All SMW-HR display data can be retrieved via communications port along with relay and EEPROM status.  
All SMW-HR user configurable data can be changed including EEPROM enable/display and relay reset. (SMW-HR Station Number cannot be changed).

The SMW-HR communications port provides for a 2 way data link. An intelligent host e.g. Personal Computer, Main Frame or PLC is able to acquire the SMW-HR's displayed value and read or modify the user configurable parameters, using any of the following:-

- a) RS232/485 - for a one to one communication (as in the case of a printer, PC or PLC).
- b) RS485 - for the connection of up to 25, SMW-HR units on a single RS485 line.
- c) 20mA Current Loop - for up to 250, SMW-HR units on a single RS232/485 line, via the IF25 interface. With high noise immunity and isolation over distances up to 1Km.

Protocols available are ASCII and MANTRABUS selectable by the CP mnemonic on the display of the SMW-HR programmer.

### **Data Retention and Protection**

Retention: 10 years for set values, minimum of 10,000 write cycles, but typically 1,000,000.

Protection of data and function(s): Watchdog timer giving repeat auto resets. Impending power fail detection and shutdown. Low power detection and hold off.

### **Environmental**

Storage temperature -20 to +70°C  
Operating temperature -10 to +50°C  
Relative humidity 95% max non condensing  
Case sealing To IP65

### **CE Approvals**

European EMC Directive 2004/108/EC  
BS EN 61326-1:2006  
BS EN 61326-2-3:2006

Low Voltage Directive 2006/95/EC  
BS EN 61010-1:2001  
Rated for Basic Insulation  
Normal Condition  
Pollution Degree 2  
Permanently Connected  
Insulation Category III

### **Physical**

Case dimensions 200 x 120 x 75mm  
Case materials Light grey ABS  
Weight 725g  
Terminals 2.5mm, saddle field terminals  
Accessibility All electronics accessible through front panel.

### **Power Supplies**

210 - 260v AC, 50 - 60Hz, 10W  
97 - 120v AC, 50 - 60Hz, 10W  
9 - 32v DC, 50 - 60Hz, 10W

## SMW-HR Order Codes

Input	Standard strain gauge		10v DC / 160mA	} SMW-HR
Outputs	Standard Analogue	Output	Range	
		DC voltage	0v to 10v	
		DC current	4 to 20mA	

## Optional Modules

### Communications Port

Current Loop	(LC1)
Multi Drop	(LC3)
RS232/485	

### Output

Control/Alarm Relay	Output 2 Relays	Function SPCO on SP1 and 2	(LR1)
---------------------	--------------------	-------------------------------	-------

## Power Supplies

220 - 240v AC 50 - 60Hz 10W	(LS1)
110 - 120v AC 50 - 60Hz 10W	
9 - 32v DC 50 - 60Hz 10W	(LS3)

Programming unit Remote Hand Held (LP3)

**Example:** UAB-EX, UAHRLC for mounting choice- please refer to the price list options  
(SMW-HR - LR1 - LC3 - LS1)

Standard SMW-HR with relay module and RS232/485 Communications and 110/240 volts AC power supply

## SMW-HR Accessories

The following accessories are available to allow for expansion of systems:

	Function	Order code
<b>IF25 Interface</b>	Connect up to 25 SMW-HRs NOTE: Details of the unit appears in a separate publication.	IF25
<b>Printers</b>	Time / date and display data Display data only	TDP DP

## Instrument Setup Record Sheet

Product	
Product Code	
Serial No	
Tag No	
Date	
Location	
Measurement type, range & engineering units	
Communication / Baud Rate	
SMW-HR	VALUE
<b>Password No 001111</b>	
trAn	
PASS	
SEtPt1	
In-Ft1	
SEtPt2	
In-Ft2	
HYSt	
LAtCH	
ACtion	
OP LO	
OP Hi	
A-tArE	
SCStdY	
rESOL	
CP	
SdSt or LAB	
Log no (for printer	
<b>Password No 009999</b>	
trAn	
PASS	
CALL	
CALH	
AdCALL	
AdCALH	
InPUtA	
dISP A	
InPUtb	
dISP b	
InPUtC	
dISPC	
InPUtd	
dISP d	
dP	
A-tArE	
SCStdY	
dISP AU	
SCStdY	
dISP AU	
rESOL	
t-SEnS	
FILtEr	

CP	
SdSt/LabEL	
Log no (for Printer)	

## WARRANTY

All SMW-HR products from Mantracourt Electronics Ltd., ('Mantracourt') are warranted against defective material and workmanship for a period of (3) three years from the date of dispatch.

If the 'Mantracourt' product you purchase appears to have a defect in material or workmanship or fails during normal use within the period, please contact your Distributor, who will assist you in resolving the problem. If it is necessary to return the product to 'Mantracourt' please include a note stating name, company, address, phone number and a detailed description of the problem. Also, please indicate if it is a warranty repair.

The sender is responsible for shipping charges, freight insurance and proper packaging to prevent breakage in transit.

'Mantracourt' warranty does not apply to defects resulting from action of the buyer such as mishandling, improper interfacing, operation outside of design limits, improper repair or unauthorised modification.

No other warranties are expressed or implied. 'Mantracourt' specifically disclaims any implied warranties of merchantability or fitness for a specific purpose. The remedies outlined above are the buyer's only remedies. 'Mantracourt' will not be liable for direct, indirect, special, incidental or consequential damages whether based on the contract, tort or other legal theory.

Any corrective maintenance required after the warranty period should be performed by 'Mantracourt' approved personnel only.



© In the interests of continued product development, Mantracourt Electronics Limited reserves the right to alter product specifications without prior notice.

Code No. 517-062	Issue 2.2	12.08.10
------------------	-----------	----------