

## Twelve Component Batch Weighing Controller

### Features

- Up to 12 components
- Optional 10 menu selection
- In Flight compensation
- Easy calibration
- Selectable batch totals
- Mixer timing
- Manual or PLC operation
- Panel display sealed to IP65
- Password protected
- Excitation for up to 4 load cells
- DIN rail relay module contact rating 230V @ 5A AC



### Introduction

Designed around the ADW15 Strain Gauge Indicator Controller, and the remote set point relay unit.

The batch controller system software makes provision for the mixing of up to 12 components in 10 possible menus (see options). Programming from the ADW-BW, keypad allows for the control of quantities from each of the feeds, and the number of batches required.

Ingredient mix times, weight checks, and settle times are all features of the comprehensive software control within the ADW-BW.

With the inclusion of interface boards, full remote control can be affected from a PC or PLC, and a printed record of all the required activity can be taken onto a printer.

### Options & Accessories

- Power supplies for 115/230V AC or 9-32V DC
- Communications port PLC or PC
- Printers drive
- Menu selection
- IF25 Interface module connects up to 25 Batch Weighing Controllers to one RS232 port

### Specifications

#### Inputs - Operating Instructions for Batch Weighing Controller

Mnemonics	Value	Description
Code		
REP	1-10	Selected recipe
PASS	1111	Security password for entry to the following data, set in EEPROM
SP1 up to 12	±19999	Set point 1 up to 12 'Desired' trip level of outputs
IF1 up to 12	±19999	In-flight compensation for SP 1 to 12 Actual trip points = SP - IF
bt	1-255	Batch total. Sets total number of batches
tl	0-19999	Mixing time set in seconds
CALL	±19999	Display value for 'Low' auto calibration point, must be less than 'CALH'
CALH	±19999	Display value for 'High' auto calibration point.
dA	0-31	Input averaging & options selection +8= BW5, +16 = 10 menu
dP	0-5	Selects decimal point position
SttI	0-255	Settle time before auto tare of next ingredient, set in seconds
tOL	0-19999	Tolerance Settings - To check mixer hopper has discharged before allowing next batch to start
bdT	1-255	Delay time before checking increase in weight on call for product. Set in seconds
lit	1-255	Increase in weight check time interval. Set in seconds 1->255
ICA	1-19999	Increase in weight check amount i.e. the display must increase in weight check time interval. (lit).Set in engineering units
Cp	0-129	
SdSt/Lab	0-254	Comms protocol 0-127 = Printer, 128 = MANTRBUS
rS	0-255	Serial device station number to set the units 'address' when the communications port is used. Sets display resolution

Note: The default display can be selected from the gross weight or the incremental net weight flowing into the receiving container

## Batch Controller System Description

The Batch Controller is based upon the load cell indicator controller ADW15 and the REM 8 multi set point DIN rail units

A special software program in the ADW15 makes provision for the mixing of up to 12 components into one mixing vessel

Each of the components is controlled by values selected under mnemonics entered from the keypad of the ADW-BW

A BCD switch with REM16I allows for the selection of up to 10 menus. The range of mnemonics include Set Points and In-flight compensation valves which, when programmed set the conditions for a relay to operate, controlling the operation of valves and therefore the amount of component from each feed into the mixer/weight vessel.

A batch control mnemonic 'bt' provides a batch total which controls the desired number of mixes from the components feeds. This value can be set from 1 to 255 batches.

The components mix time can be set from between 0 to 19999 seconds, by the setting of the mnemonic 'tl', before a discharge is activated.

Auto calibration of the ADW15 controller is achieved by 'low' and 'high' calibration point settings.

Further mnemonics allow for a display averaging and decimal point position, and settle time figure before call of the next component.

Calibration	Automatic digital by use of keypad and 1 (or 2) known weights. Manual calibration can also be selected
Sensitivity	Preset via DIL switches between 0.5 to 200mV/V
Excitation	10V dc nominal, 150mA maximum
Compensation	By $\pm$ sense wires to compensate for cable, connection volt drops and any variation in 10V supply
Accuracy	90 days $\pm$ 0.08% of reading $\pm$ 0.05% of FSD typical
Drift	0.002% $^{\circ}$ C typical @ 2.5mV/V
Display Rate	0.1 seconds for standard update
Input Average	Set by keypad up to 64 standard updates
Display	1 x 4.5 digit, High brightness, 10mm Red LED, 2 x 3mm LED's for SP1 and SP2 status, 1 x 3mm LED for hold

## The Relay Output Modules

The module consists of 8 relays rated at 230 volts 5 Amps - SPCO, Alarm via 30V 50mA NC contact, DIN rail mounted for a G or top hat profile. Each relay is plug-able and connections are made by 2.5mm field screw terminals.

Indication of relay status is shown by LED's. Trip points volt free contact. The module can be situated up to 2 metres from the ADW15 load cell indicator controller.

Dimensions for the DIN Rail Relay Output Module

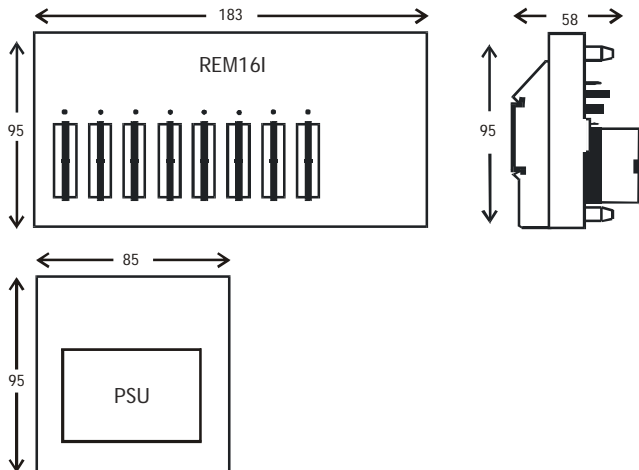

Panel Mount Dimensions for the ADW15

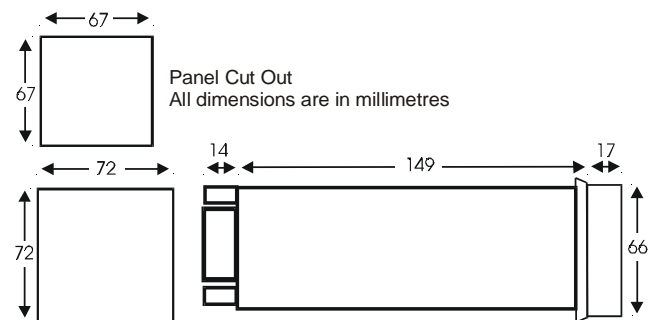

CE *In the interest of continued product development, Mantracourt Electronics Limited reserves the right to alter product specifications without prior notice.*