

Description

The SPB-8 is a medium range aluminium alloy single point load cells, which has been specifically designed for platform weighing applications, although it is equally suited to other weighing and force measurement applications where high accuracy is required from a low cost product.

The SPB-8 is suitable for use in platforms with sizes up to 350mm x 350mm. It is environmentally sealed as standard to IP66.

The SPB-8 series can be supplied on it's own or combined with our extensive range of instrumentation to provide a complete load monitoring system.

SPB-8 Medium Range Single Point Load Cell

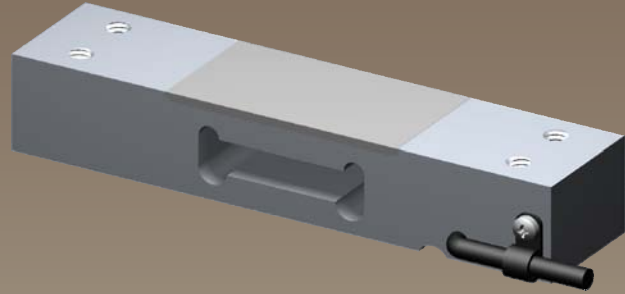

Features

- Ranges 3, 5, 7, 10, 15, 20, 30, 35, 50, 100, 150, 200kg
- Aluminium Construction.
- Environmentally Sealed to IP66
- High Accuracy ($< \pm 0.02\%$)
- Suitable for use in platforms, maximum size 350mm x 350mm
- Only 22mm high

Typical Applications

- Low profile platform scales
- Hanging scales
- Tension measurement (fold back arms)
- Web tension measurement

Medium Range Single Point Load Cell

Specification

Rated Load (kg):	3, 5, 7, 10, 15, 20, 30, 35, 50, 100, 150, 200
Proof Load:	150% of Rated Load
Ultimate Breaking Load:	300% of Rated Load
Output:	2 mV/V at Rated Load ($\pm 10\%$)
Accuracy:	$< \pm 0.02\%$ of Rated Load
Non-Repeatability:	$< \pm 0.01\%$ of Rated Load
Excitation Voltage:	10vdc recommended, 15vdc maximum
Bridge Resistance:	415 Ω
Insulation Resistance:	$> 500M\Omega$ @ 100vdc
Operating Temperature Range:	-20 to +70°C
Compensated Temperature Range:	-10 to +40°C
Zero Temperature Coefficient:	$< \pm 0.003\%$ of Rated Load/°C
Span Temperature Coefficient:	$< \pm 0.001\%$ of Rated Load/°C
Environmental Protection Level:	IP66
Connection Type:	PVC screened cable 0.5m long

Mechanical Dimensions

All dimensions in millimeters

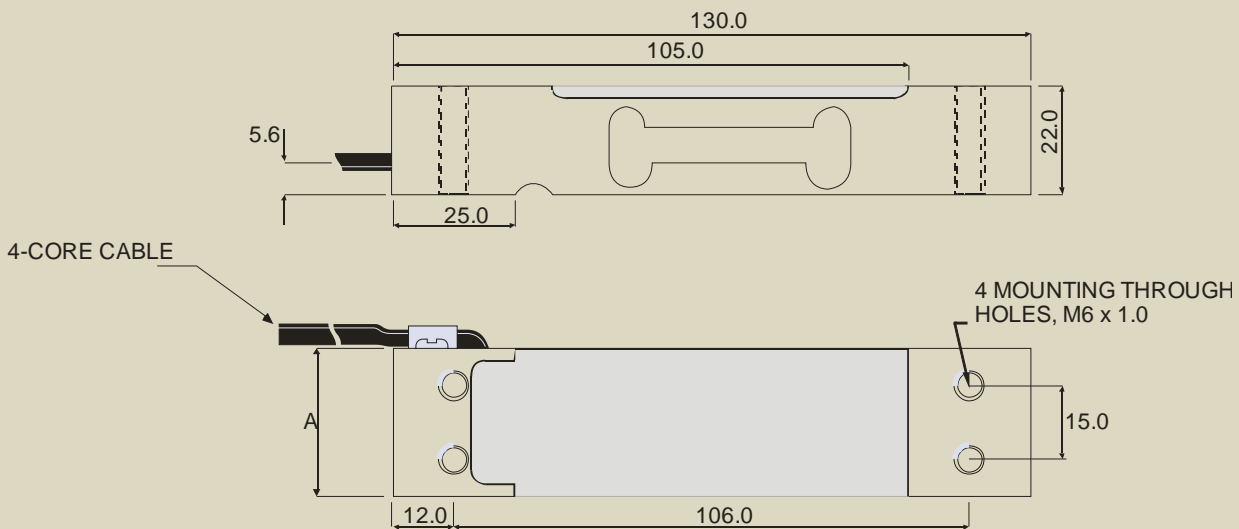

CAPACITY	A
3, 5, 7kg	25.4
10, 15, 20, 30kg	30.0
35 - 200kg	40.0

Due to continual product development, LCM Systems Ltd. reserves the right to alter product specifications without prior notice.

Issue Date: 20/3/2009

Unit 15, Newport Business Park
 Barry Way, Newport, Isle of Wight, PO30 5GY
 United Kingdom
 Tel: +44 (0) 1983 249264
 Fax: +44 (0) 1983 249266
 Email: sales@lcmsystems.com

LCM
 SYSTEMS

www.lcmsystems.com

TYPE: SPB-8