

Description

General

This modular amplifier system offers the user, the opportunity to tailor-make a signal processing and control instrument to an exact requirement, from the simple, to the most comprehensive. It is analogue based with input boards configured to provide outputs on a motherboard bus in the range 0-10Vdc.

The modular construction allows retrospective additions to the system, with expansion in mind. The system consists of a rigidly supported motherboard with a selection of daughter boards plugged into headers, to perform various functions as required by a specific application. After selection and test, each daughter board is mechanically held in position with a rigid clamp.

Construction

The motherboard PCB has an on-board power supply section, which allows the system to be run from 12Vdc, 24Vdc or 110/240Vac. These options need to be defined at the time of ordering. Two sizes of motherboards are available with capacity for 5 or 11 plug-in modules. Each completed system is housed in a die-cast aluminium enclosure of 125mm wide by 80mm high (either 220mm or 360mm long) with a protection rating of IP65. Wiring is through nickel-plated cable glands and into numbered terminal blocks on each daughter board.

Bus System

A multi-way signal, control and power bus travels the length of the motherboard. Up to 4 input boards can be fitted plus a summation and/or switching board which feed dedicated channel or group busses. A test board would be fitted to enable monitoring of all the bus lines with a multi-meter.

Various output daughter boards can be fitted to provide voltage, current or meter outputs as well as an RS232/422 serial board that can drive digital displays and interface to a PC. Trip relay, bargraph ladder and 3 level light driver boards can also be fitted as required.

Typical Applications

- Crane load monitoring/control
- Hoist control systems
- Multi-channel load cell conditioning
- Balancing systems

MAX Modular Analogue Expandable System

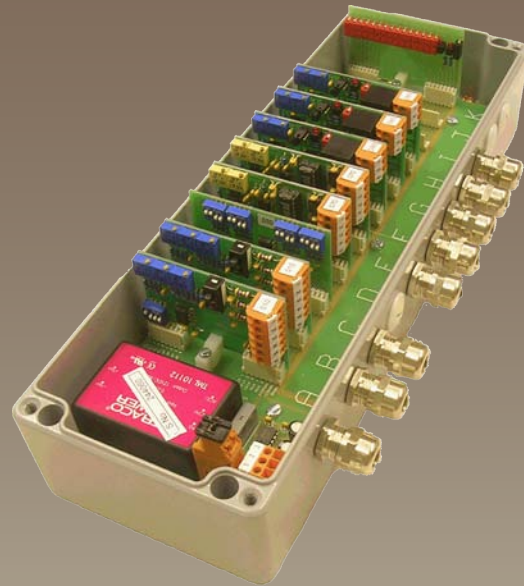

Features

- Modular System with plug-in modules
- Two Motherboard Sizes giving capacity for 5 or 11 plug-in modules
- Totally user configurable
- Housed in IP65 die-cast enclosure
- Input modules include: load cell, current & resistive high accuracy
- Control modules include: summation, external switching & trip set
- Output modules include: voltage, current, serial, relay, meter, traffic light & ladder

Modular Analogue Expandable System

Enclosures and Motherboards

The MAX modular system is supplied in two different sizes providing a maximum set-up of either 5 or 11 daughter boards into a motherboard. One of these slots will normally be used for the test board in each case. All enclosures are of die cast aluminium with an environmental rating of IP65. The drawings below show 1 daughter & 1 test board fitted.

11 way Motherboard System

Part Number	Description
MAX-151	11 way motherboard 12vdc powered
MAX-152	11 way motherboard 24vdc powered
MAX-153	11 way motherboard 110/240vacpowered

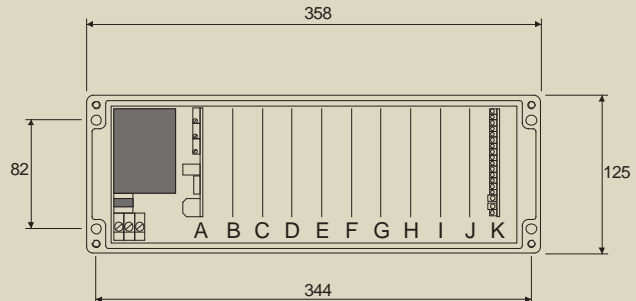

5 way Motherboard System

Part Number	Description
MAX-161	5 way motherboard 12vdc powered
MAX-162	5 way motherboard 24vdc powered
MAX-163	5 way motherboard 110/240vacpowered

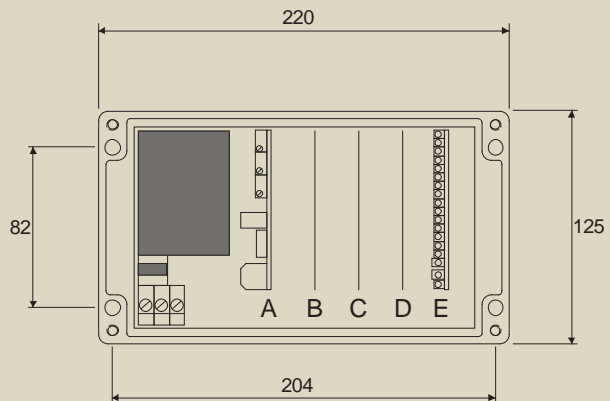

Note: All motherboards are supplied complete with the enclosure, power supply and test board

Test Board Details

The test board enables the monitoring and setting up of all the bus voltages. There are two LED's that indicate the power to the bus.

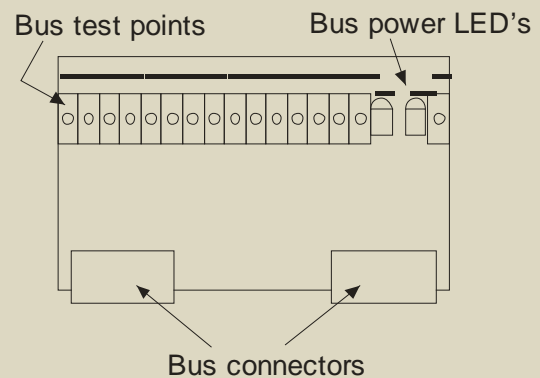

Input Modules

Up to four input modules can be fitted to a motherboard making their outputs available onto any of the 4 ways of the channel bus. The outputs address of each module (channel bus address) is set via a DIL switch on each module.

MAX-010 - Load Cell Input

This module provides the excitation supply for and is suitable for use with any strain gauge based sensor. There is an internal CAL switch, which enables the shunting of an internal sensor calibration resistor. Adjustments are available for zero and fine/coarse gain. Switches designate which channel bus the input module is assigned to

Specifications

Input sensitivity range	0.2m V/V to 4mV/V
Adjustment controls	Zero & fine/coarse gain
Zero adjustment	$\pm 0.1\text{mV/V}$
Bridge excitation voltage	10Vdc @ 100mA
Bridge resistance	120 Ω to 1000 Ω
Current consumption	2mA + bridge supply current

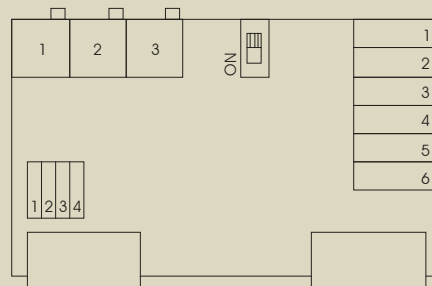

MAX-020 - Current Input

This module accepts the output from any current output device, between the ranges shown below. There is an internal CAL switch, which enables the shunting of an external calibration check resistor (where this is available on interfacing electronics). Adjustments are available for zero and gain. Switches designate which channel bus the input module is assigned to.

Specifications

Input sensitivity range	0mA to 20.9mA
Adjustment controls	Zero & gain
Zero adjustment	$\pm 5\text{mA}$
Supply voltage	+12Vdc
Input resistance	100 Ω
Current consumption	12mA + input supply current

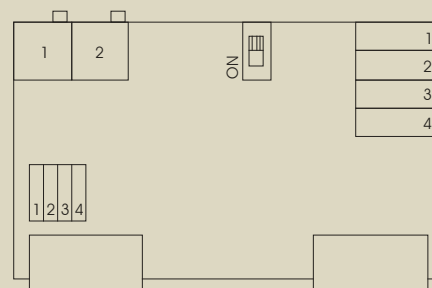

MAX-025 – Instrumentation Input

This module provides the excitation supply for and is suitable for use with any strain gauge or resistance-based sensor. There is an internal CAL switch, which enables the shunting of an internal sensor calibration resistor. Adjustments are available for zero and fine/coarse gain. Switches designate which channel bus the input module is assigned to. This is a high specification version of MAX-010.

Specifications

Input sensitivity range	0.2mV/V to 17mV/V
Adjustment controls	Zero & fine/coarse gain
Zero adjustment	$\pm 0.5\text{mV/V}$
Bridge excitation voltage	10Vdc @ 100mA
Bridge resistance	120 Ω to 1000 Ω
Current consumption	2mA + bridge supply current

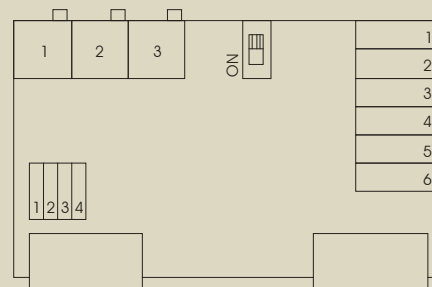

Control Modules

Control modules take the outputs from the input modules on the channel bus, process the signals and feed them to an appropriate Output module, via the bus.

MAX-030 - Summation

This module contains four independent summation amplifiers, feeding their outputs to selected Group Busses. By setting the appropriate DIL switches up to four combinations can be selected from any of the four input modules. The output on any group is equal to the average of that group's selected channel outputs.

Specifications

Input	From any MAX input mode
Adjustment controls	None
Gain adjustment	2mA

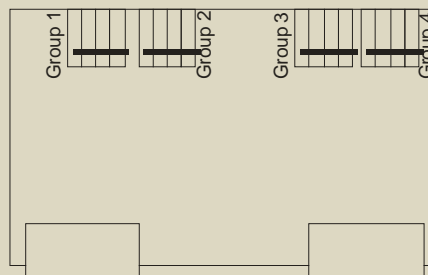

MAX-035 – 8 Way Switching Board

This module allows the switching of up to seven different outputs from the Channel Bus and/or the Group Bus to any vacant part of the Channel Bus or the Group Bus with a differential gain potentiometer between the chosen busses. An external 3-bit logic switch selects any one of the seven outputs and routes it to the chosen vacant bus.

Specifications

Input	From any MAX input mode
Adjustment controls	Channel and Group gain
Gain adjustment	0% to 100%
External controls	Channel/Group selector switch
Current consumption	6mA

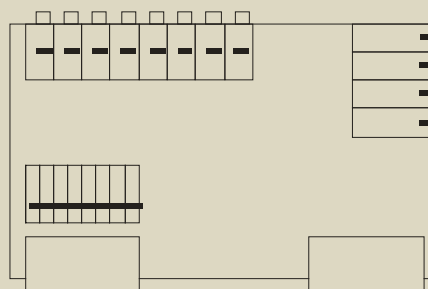

MAX-040 – Trip Set

This module contains the adjustments to allow up to eight different trip output voltages to be set as ratios of the expected full-scale output. An external 3-bit logic switch selects one of these eight voltages and applies it to Trip 1 Bus. User defined ratios of the Trip 1 Bus voltage are applied to Trip 2 Bus and Trip 3 Bus, normally 90% and 5% respectively.

Specifications

Input	From any MAX input mode
Adjustment controls	Trip output
Trip adjustment range	0% to 100%
External controls	Channel/Group selector switch
Current consumption	20mA

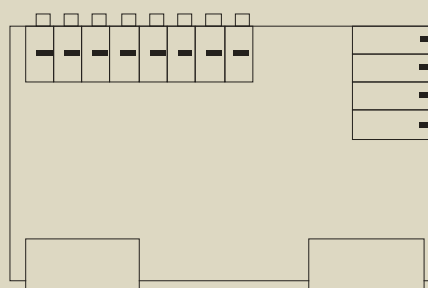

Output Modules

Modules MAX-050, 060, 070 and 090 provide scaled outputs proportional to the voltages available on either the channel or group busses.

Modules MAX-080, 100 and 110 provide outputs that compare the voltages on the channel and group busses to either the trip bus or to local pre-set voltages.

Any number of these modules can be fitted to a system. Some have been designed to drive specific LCM displays and warning devices, whilst others provide standard analogue and digital outputs, which can interface with a wide range of industry standard instrumentation.

MAX-050 – Voltage Output

This module provides three different voltage output options with the ability to scale the output proportional to the input voltage or sensor measurement range. A DIL switch selects which channel or group is connected to this module.

Specifications

Output ranges	$\pm 2V$, $\pm 5V$ or $\pm 10V$
Adjustment controls	Fine gain
Gain adjustment range	$\pm 2\%$
Output drive current	1mA max.
Current consumption	4mA

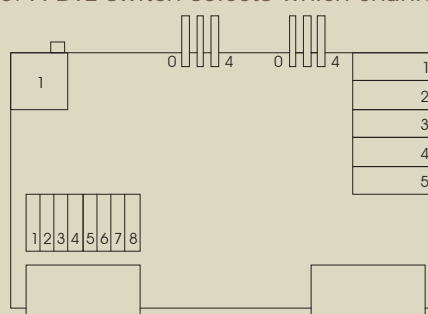

MAX-060 – Current Output

This module provides either 0-20mA or 4-20mA output proportional to the input voltage or sensor measurement range. A DIL switch selects which channel or group is connected to this module.

Specifications

Output ranges	0-20mA or 4-20mA
Adjustment controls	Fine gain
Gain adjustment range	$\pm 2\%$
Output drive resistance	500 Ω max
Current consumption	8mA + output current

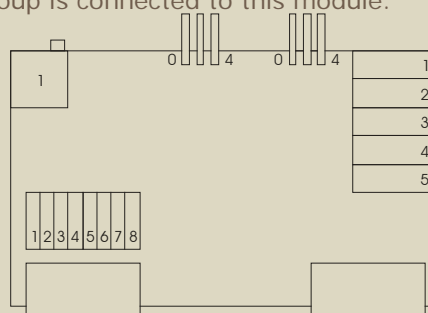

MAX-070 – Serial Output

This module outputs a continuous data stream in both RS232 and RS422 formats. The RS422 data stream is specifically designed to drive LCM pendant control display and large digit displays. A gain control and range setting jumpers allow the output data to be numerically scaled to the input voltage. A DIL switch selects which channel or group is connected to this module.

Specifications

Output format	RS232 and RS422
Data range	2400 baud
Data format	8 data bits, no parity, 1 stop bit
Multi drop capabilities	RS422, to 10 remote stations
Adjustment controls	Zero and coarse/fine gain
Ancillary voltage supply	+12Vdc
Current consumption	75mA + ancillary supply current

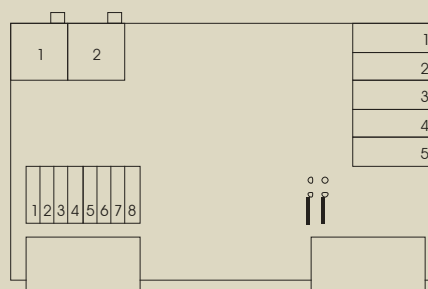

MAX-080 – Relay Output

This module is fitted with single volt free SPCO relay. The signal to drive this module can come from either the channel or group busses as selected using the DIL switch. The trip level reference can be derived remotely via the trip bus or locally. Either normal or fail-safe mode can be set via a jumper link.

Specifications

Contact type	Volt free SPCO
Relay contact rating	10A at 28Vdc/120Vac
Reference voltage range	0V to 10V
Current consumption	44mA

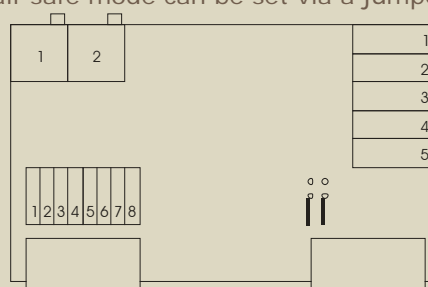

MAX-090 – Meter Output

This module provides a 0-2Vdc output for a full-scale input. It is specifically designed to drive the LCM CDA-308 digital LCD display but is suitable for driving an analogue meter of typically 1mA fsd. A DIL switch selects which channel; group or trip bus line is connected to this board. A gain control allows the output to be scaled to the input voltage or sensor measurement range. A capacitor change can modify output damping.

Specifications

Output range	0-±20mV to 0-±2V
Adjustment controls	Coarse and fine gain
Ancillary voltage supply	12Vdc, ±5Vdc @ 100mA
Current consumption	14mA + Ancillary supply current

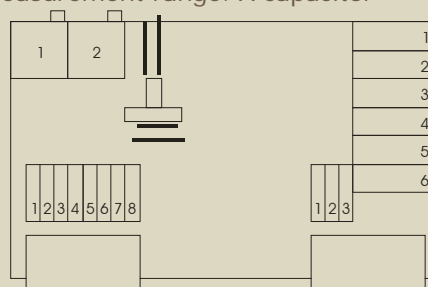

MAX-100 – Traffic Light Output

This board is used to drive a 3 level lamp and buzzer pendant such as the LCM - RAG (red, amber & green). The signal to drive this module can come from either the channel or group busses as dictated by the DIL switch. The trip level references can be either set locally (where the green and amber are fixed ratios of the red setting) or remotely via the trip bus.

Specifications

Output Type	Open Collector Outputs (12Vdc)
Output drive capability	100mA
Reference voltage range	0V to 10V
Ancillary Voltage Supply	+12Vdc
Current consumption	32mA + ancillary supply current

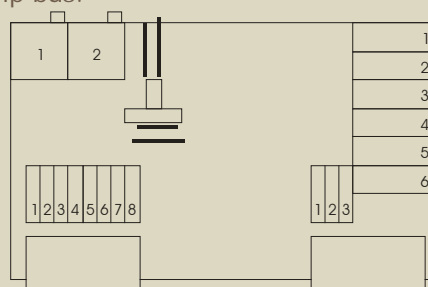

MAX-110 – Ladder Output

This module is used to drive a graduated LED bar graph display, either positive going or bi-directional (centre-zero). The signal to drive this module can come from either the channel or group busses as dictated by the DIL switch. The full-scale reference can be either set locally or remotely via the trip bus.

Specifications

Output Type	0-10Vdc (1mA max)
Reference voltage range	0V to 10V
Ancillary Voltage Supply	+12Vdc
Current consumption	8mA + ancillary supply current

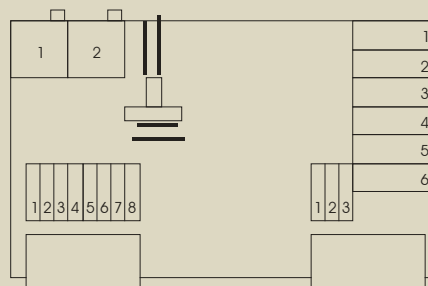

Due to continual product development, LCM Systems Ltd. reserves the right to alter product specifications without prior notice.

Issue Date: 24/9/2008

Unit 15, Newport Business Park
Barry Way, Newport, Isle of Wight, PO30 5GY
United Kingdom
Tel: +44 (0) 1983 249264
Fax: +44 (0) 1983 249266
Email: sales@lcmsystems.com

LCM
SYSTEMS