

Description

The LCM range of CTW compression load cells have been specifically designed for weighing and process measurement applications.

The CTW offers superb performance with regards to accuracy and environmental protection. The stainless steel design and fully welded assembly offers protection levels to IP67. Higher capacity ranges are available in our CPA series, which covers ranges to 1000te.

The CTW can also be supplied with a complete instrumentation system, giving the customer a single source for their complete system. Contact our technical department to discuss your instrumentation and control requirements.

CTW Compression Column Load Cell

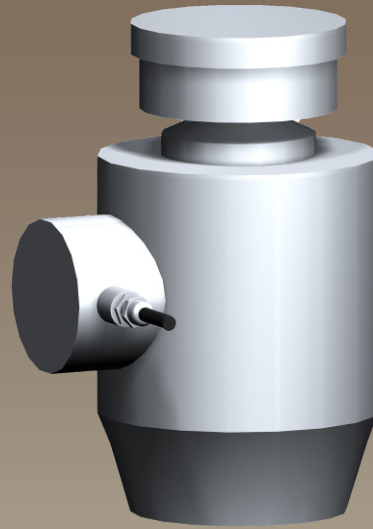

Features

- Ranges 5, 10, 20, 30, 50te
- Environmentally Sealed to IP67
- Rationalised output
- Internal surge arrestors fitted

Typical Applications

- Process weighing
- Silo weighing
- Centre of gravity systems
- Multi point structural weighing
- Press force calibration

Compression Column Load Cell

Specification

Rated Load (tonne)	5, 10, 20, 30, 50
Proof Load:	150% of Rated Load
Ultimate Breaking Load:	>300% of Rated Load
Output:	1.5 mV/V at Rated Load ($\pm 0.15\%$)
Accuracy:	$< \pm 0.05\%$ of Rated Load
Non-Repeatability:	$< \pm 0.03\%$ of Rated Load
Excitation Voltage:	10vdc recommended, 24vdc maximum
Input Resistance:	670 Ω ($\pm 15\Omega$)
Output Resistance:	605 Ω ($\pm 5\Omega$)
Insulation Resistance:	>500M Ω @ 100vdc
Operating Temperature Range:	-20 to +70°C
Compensated Temperature Range:	-10 to +40°C
Zero Temperature Coefficient:	$< \pm 0.010\%$ of Rated Load/°C
Span Temperature Coefficient:	$< \pm 0.005\%$ of Rated Load/°C
Environmental Protection Level:	IP67
Connection Type	Integrally glanded PUR cable 10m long
Construction:	Stainless steel housing, plated steel element

Mechanical Dimensions

All dimensions in millimeters

5-30te Dimensions

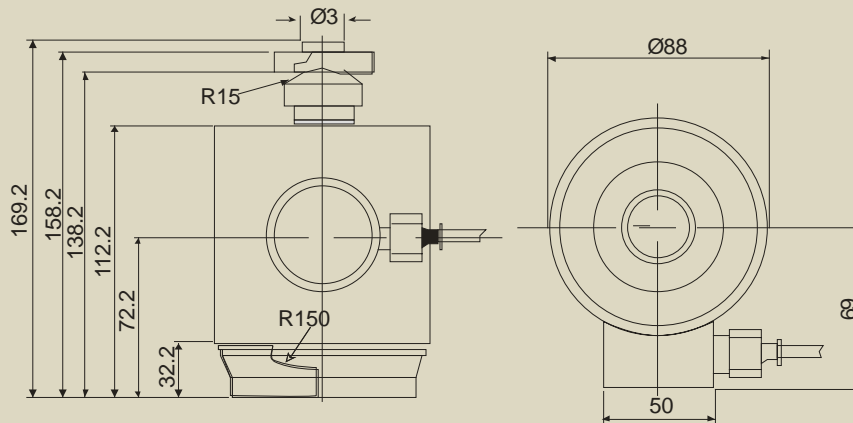

50te Dimensions

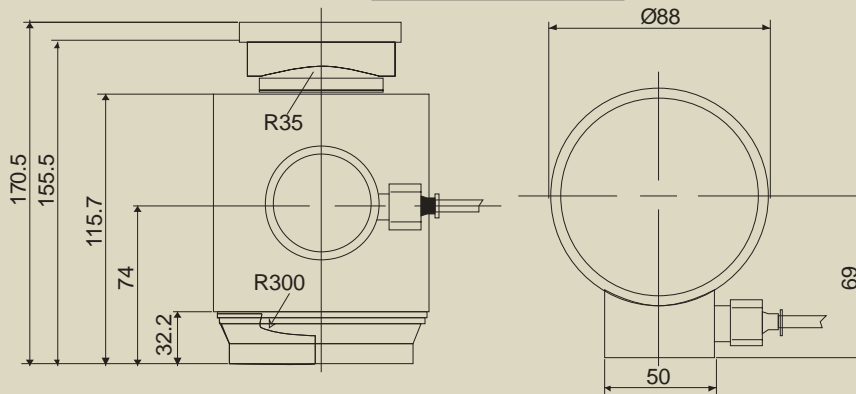

Due to continual product development, LCM Systems Ltd. reserves the right to alter product specifications without prior notice.

Issue Date: 24/9/2008

Unit 15, Newport Business Park
 Barry Way, Newport, Isle of Wight, PO30 5GY
 United Kingdom
 Tel: +44 (0) 1983 249264
 Fax: +44 (0) 1983 249266
 Email: sales@lcmsystems.com

LCM
 SYSTEMS

www.lcmsystems.com

TYPE: CTW