

Description

The LCM range of CBR compression bending ring load cells have been specifically designed for vessel/silo weighing and weighbridge applications, where low height is essential, without compromising on accuracy.

The CBR offers superb performance with regards to accuracy and environmental protection. The stainless steel design and fully welded assembly offers protection levels to IP68.

There are various mounting assemblies available for the CBR, enabling customers the opportunity to install the CBR quickly and realise the best accuracy and performance from the product.

The CBR can also be supplied with a complete instrumentation system, giving the customer a single source for their complete system. Contact our technical department to discuss your instrumentation and control requirements.

CBR Compression Bending Ring Load Cell

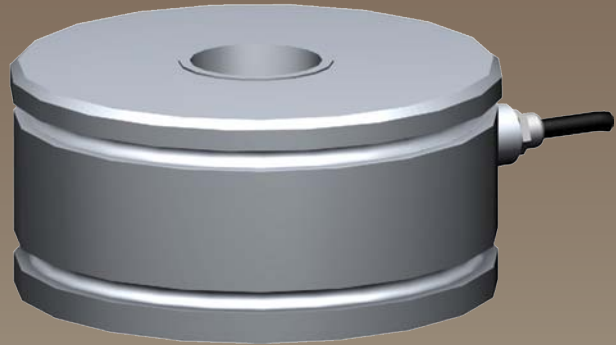

Features

- Ranges 5000, 10000, 20000, 30000kg
- Stainless steel fully welded construction
- Sealed to IP68
- Rationalised output
- 1000ohm bridge resistance
- Small size and low profile
- Silo/vessel mounting assembly option available

Typical Applications

- Vessel Weighing
- Silo Weighing
- Centre of gravity weighing systems
- Multi point structure weighing
- Test machine/press calibration

Compression Bending Ring Load Cell

Specification

Rated Load (kg):	5,000, 10,000, 20,000, 30,000
Proof Load:	150% of Rated Load
Ultimate Breaking Load:	>300% of Rated Load
Output:	2 mV/V at Rated Load (± 0.1)
Accuracy:	$< \pm 0.02\%$ of Rated Load
Non-Repeatability:	$< \pm 0.01\%$ of Rated Load
Excitation Voltage:	10vdc recommended, 20vdc maximum
Bridge Resistance:	1000 Ω
Insulation Resistance:	>500M Ω @ 100vdc
Operating Temperature Range:	-30 to +70°C
Compensated Temperature Range:	-10 to +40°C
Zero Temperature Coefficient:	$< \pm 0.002\%$ of Rated Load/°C
Span Temperature Coefficient:	$< \pm 0.002\%$ of Rated Load/°C
Environmental Protection Level:	IP68
Connection Type:	PUR screened cable Length 5m (5000kg) 10m (10000 & 20000kg) 20m (30000kg)
Options Available:	Vessel/Silo mounting assembly

Mechanical Dimensions

All dimensions in millimeters

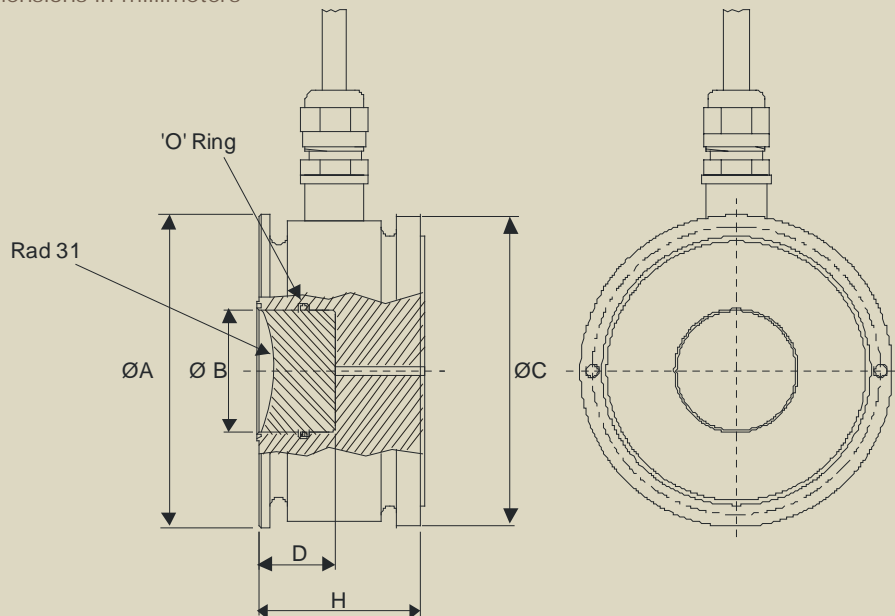

	5t	10t	20t	30t
ØA	80	92	110	110
ØB	19	28	29	29
ØC	70	80	101.5	101.5
D	20	14.6	26.3	26.3
E	33.4	33.4	39	39
H	30	33	50	50

Due to continual product development, LCM Systems Ltd. reserves the right to alter product specifications without prior notice.

Issue Date: 24/9/2008

Unit 15, Newport Business Park
Barry Way, Newport, Isle of Wight, PO30 5GY
United Kingdom
Tel: +44 (0) 1983 249264
Fax: +44 (0) 1983 249266
Email: sales@lcmsystems.com

LCM
SYSTEMS

www.lcmsystems.com

TYPE: CBR